

MAINTENANCE AND OPERATION
INSTRUCTION MANUAL

DB7012

Professional DSP-based DAB/DAB+
Monitoring Receiver



Contents

Introduction	5
Typographic conventions	6
General Information	7
Product Features	8
<i>Technical Specifications</i>	9
<i>Block Diagram</i>	10
Safety Warning	11
Panel Indicators, Switches and Connectors	12
<i>Indicators</i>	12
<i>OLED Display</i>	12
<i>LED Meters</i>	12
<i>Context-sensitive soft buttons</i>	12
<i>Navigational buttons</i>	12
<i>Rear Panel</i>	13
<i>Rear Panel Alarm Terminal</i>	14
Operating Recommendations	15
Unpacking and inspection	16
Mounting	16
<i>Rack Requirements 1U</i>	16
<i>Rack Requirements Compact Units</i>	16
<i>Stand-Alone Devices</i>	16
AC Mains Power	17
<i>Fuse holder</i>	17
<i>Mains Voltage Selector</i>	17
<i>Power cord</i>	17
<i>Ground Loops</i>	17
Getting Started	18
<i>Connection</i>	18
<i>Network Settings</i>	19
<i>Network Discovery</i>	19
<i>Network Security Recommendations</i>	20
Basic Setup	21
<i>OLED Display</i>	21
<i>How to change device parameters</i>	21
<i>Set-up menu title</i>	21
<i>Navigation area</i>	21
<i>Home Screen</i>	25
<i>Main Screen working area</i>	27
<i>Soft Buttons</i>	27
<i>Navigation Buttons</i>	27
<i>Menu Pages</i>	28
<i>Tuner</i>	28
<i>Output</i>	29
<i>Setup</i>	29
<i>Security</i>	30

Keyboard lock.....	30
Keyboard unlock.....	30
Monitoring.....	31
Alarms set-up – Option 1.....	32
Alarms set-up – Option 2.....	32
Status.....	33
WEB Interface menu pages.....	34
Device control interface.....	34
Main.....	36
Loudness.....	37
Ensemble.....	38
Service.....	39
Band Scan.....	40
Status.....	41
Log.....	42
General Settings.....	43
Tuner settings.....	44
Logger.....	45
Logger Service Settings (Service 1).....	46
Communication Settings.....	48
Outputs settings.....	50
Other settings.....	51
APPENDIX B.....	52
Alarm Triggers.....	52
Alarm Notifications.....	54
APPENDIX C.....	55
GSM Modem Option - Features and Usage.....	55
Remote Status Request.....	56
Initialization procedure for Sierra Wireless AirLink FXT009 GSM modem.....	57
1. Setting up the modem.....	57
2. Connecting with DEVA Unit.....	59
APPENDIX D.....	60
How should I configure the connection between my DEVA Device and an FTP Client?.....	60
WARRANTY TERMS AND CONDITIONS.....	62
Product Registration Card.....	63

THIS PAGE
IS INTENTIONALLY
LEFT BLANK

Introduction

DEVA Broadcast Ltd. is an international communications and high-technology manufacturing organization, its corporate headquarters and facility located in Burgas, Bulgaria. The company serves the broadcast and corporate markets worldwide – from consumers and small businesses to the largest global organizations. It is dedicated to the research, design, development and provision of advanced products, systems and services. DEVA Broadcast launched its own brand back in 1997 and has nowadays evolved to become known as a market leader and internationally reputed manufacturer of user-friendly, cost-effective and innovative broadcast products.

Creativity and innovation are deeply woven into DEVA Broadcast corporate culture. Through successful engineering, marketing and management our team of dedicated professionals creates future-oriented solutions to improve customers' performance. You may rely that all issues communicated to our crew would be addressed accordingly. We pride ourselves on our pre and post-sales support and purchase services, which along with the outstanding quality of our radio gear have won us due respect and the market authority position.

DEVA Broadcast best-of-breed solutions have become the best sellers for our partners. The strategic partnerships which have been formed with industry leaders during all these years that we have been operating on the broadcasting market, have proved us a reliable business partner and a valuable asset, as our dealers worldwide would confirm. In constant pursuit of precision and long-term satisfaction, DEVA Broadcast enhances the reputation of our partners and clients alike. Furthermore, we have already a proven merit as a credible partner provider.

Our portfolio offers complete line of high quality and competitive products for FM and Digital Radio, Radio Networks, Telecommunication Operators and regulation authorities. For almost two decades of intensive software and hardware development, we have achieved a unique price-performance and endurance of our product lines. Our company's multitude of equipment and services is in line with the latest technologies and key trends. The most recognizable characteristics attributed to DEVA Broadcast products are their clear-cut, streamlined design, easiness of use and cost-effectiveness: simplicity of forms but multiplicity of functions.

For us there is no stage when we deem that we have reached the most satisfactory level in our work. Our engineers are in constant pursuit of new ideas and technologies to be captured in DEVA Broadcast solutions. Simultaneously, a strict control is being exercised at each step of any new development. Experience and hard work are our fundament but the continuous improving process is what we never leave aside. DEVA Broadcast participates on a regular basis in all landmark broadcasting events, not only to promote its products, but to exchange valuable know-how and experience. We are also engaged in international large-scale projects involving radio and audio solutions which makes us even more competitive on the global market.

All DEVA Broadcast products are developed and produced in accordance with the latest ISO 9001 quality control standards.

Typographic conventions

The following table describes important conventions used in the manual.

Convention and Style	Description	Examples
<i>Menu > Sub Menu > Menu Command</i>	A menu item(s) and menu command that you need to click in sequence	Click <i>Settings > General</i>
[Button]	Interface Interactive buttons	Press [OK] to save the changes
NOTE	Important notes and recommendations	NOTE: The notification will appear only once
<u>“Reference Name” on Page XXX</u>	References and links	refer to <u>“New Connection”</u> (see <u>“Monitoring” on page 56</u>)
Example	Used when example text is cited	Example for E-mail Notification: Date: 04 Nov 2013, 07:31:11

General Information

DEVA's DB7012 – Professional DAB/DAB+ Monitoring Receiver is an elegant and smart monitoring solution specifically developed by our engineers to fully comply with the Digital Audio Broadcasting standard while strictly adhering to the signature features underlying the company's products. A highly practical design coupled with a wide range of features makes this device a guarantee of slick and smooth performance.

As a leading manufacturer of advanced broadcasting technology, it is DEVA's aim to constantly supply top-of-the-range gear in keeping with the major industry trends, which is why our team has created a top-quality line of products dedicated to Digital Radio Broadcasting. As part of that line, the DB7012 fully meets the ETSI EN 300 401 DAB standard. Additionally, it offers support for Program Associated Data (PAD), as well as all standard bitrates and VBR and automatically displays live metadata. While the signal is being monitored and logged, the DB7012 measures the following DAB signals: RSSI, SNR, CNR, FIC Quality, FIB Errors, FFT Offset and the Left & Right Audio level values and stores them, thereby allowing for future analysis. The collected data can easily be downloaded via a standard FTP client. As an additional feature, the tool guarantees that there is no interruption of the broadcast signal. This is achieved through the provided local alarm options and online notifications via rear-panel alarm GPOs, E-mail and SNMP in case there is audio loss or change in the DAB signal and the Left and Right Audio Levels. Therefore, maintenance staff can be quick to respond and prevent prolonged signal loss.

The BandScan function of the DB7012 presents an overview of all DAB/DAB+ signals available, plus their RF signal strength. BandScans are possible within any section of Band III. The generated spectrum diagram shows the RF Level vs. the channels.

In addition to its wide array of features, the DB7012 receiver is easy to control and setup. The unit can be programmed through the front-panel menu or remotely through your PC, tablet or smart phone via a standard web browser; iOS and Android devices are also supported. The design of the DB7012 incorporates a high-resolution OLED graphical display and three ultra-bright LED bar graph indicators which allow for easy reading of the main signal parameters. A user-friendly front panel menu in addition to the set of four soft buttons provides easy navigation through the menus and quick access to each function.

Based on our engineers' relentless pursuit of improvement and their vast experience with delivering high-end gear to a demanding and competitive market, the DB7012 offers a successful combination of top monitoring performance and user-friendly operation.

Product Features

- DAB/DAB+ compliant receiver
- Support for Program Associated Data (PAD)
- Predefined DAB channels scan or manual tune
- Detailed DAB component information
- High-end digital tuner
- Wide angle, easy to read OLED display
- Very Intuitive Navigational Menu
- Quick Service access via 4 Presets
- Real Time Audio Program Streaming
- Built-in easy to use WEB and FTP server
- Apple and Android devices support
- Protected access to the device settings
- Wide operating voltage range: 100-240V AC
- Bright bar graph LED metering of the RF and Audio Levels
- Headphone output with front panel level control
- SNTP for automatic synchronization of the built-in clock
- Level Adjustable, Balanced Analog Audio Outputs on XLR Connectors
- Professional AES/EBU Digital audio output
- LAN port for full TCP/IP remote control and monitoring
- Adjustable MIN/MAX alarms for RF, Left & Right Audio Levels
- Alarm dispatch via E-mail, SNMP ver.2C and GPO
- Firmware updates will ensure improved operation

TECHNICAL SPECIFICATIONS

DAB/DAB+ RADIO	
RF frequency range	168 - 240 MHz
DAB/DAB+	Band III Channels 5A - 13F
Sensitivity	18 dB μ V
Input connector	BNC 50 Ω
In compliance with	ETSI EN 300 401
Ensemble acquisition Time	940 ms
L&R Audio	1%, +5.0 to -50.0 dB, 0.1 dB resolution
DAB/DAB+ METERING	
Quality indicators	RSSI, SNR, CNR, FIC Quality, FIB Errors, FFT Offset
PAD	DLS, MOT
Metadata Displayed	Ensemble Label, Component List & ID, Service List & ID, Dynamic Label, PTY, Sample Rate, Bit Rate, Gain, Mode, Service Mode, Protection Info, Current CU & Address, Country, Language, Time & Date
OUTPUTS	
Analog Audio Outputs (L, R)	+10 dBu, balanced XLR Connector
AES/EBU Output (L,R)	5.0 Vp-p, 110 Ω , balanced XLR Connector
Alarms	Programmable terminals on rear panel, Optoisolated
Headphone	6,3mm (1/4") Phone Jack
NETWORK	
Connector	RJ-45
Type	Ethernet
Device discovery	UPnP support
MEASUREMENTS AND LOG STORAGE	
Storage	2GB Build-in Memory Card
Data format	Text, CSV
OPERATING CONDITIONS	
Temperature	-15°C to 55°C
Humidity	< 95%, non-condensing
Altitude	0 to 5000m above sea level
POWER	
Voltage	100-240V / 50-60 Hz
Power Consumption	20VA
Connector	IEC320, Fused and EMI-suppressed
SIZE AND WEIGHT	
Dimensions (W;H;D)	485 x 44 x 300 mm
Shipping Weight	540 x 115 x 300 mm / 2.660kg
HS Code	8527212000

BLOCK DIAGRAM

A simplified block diagram of DB7012 is shown below

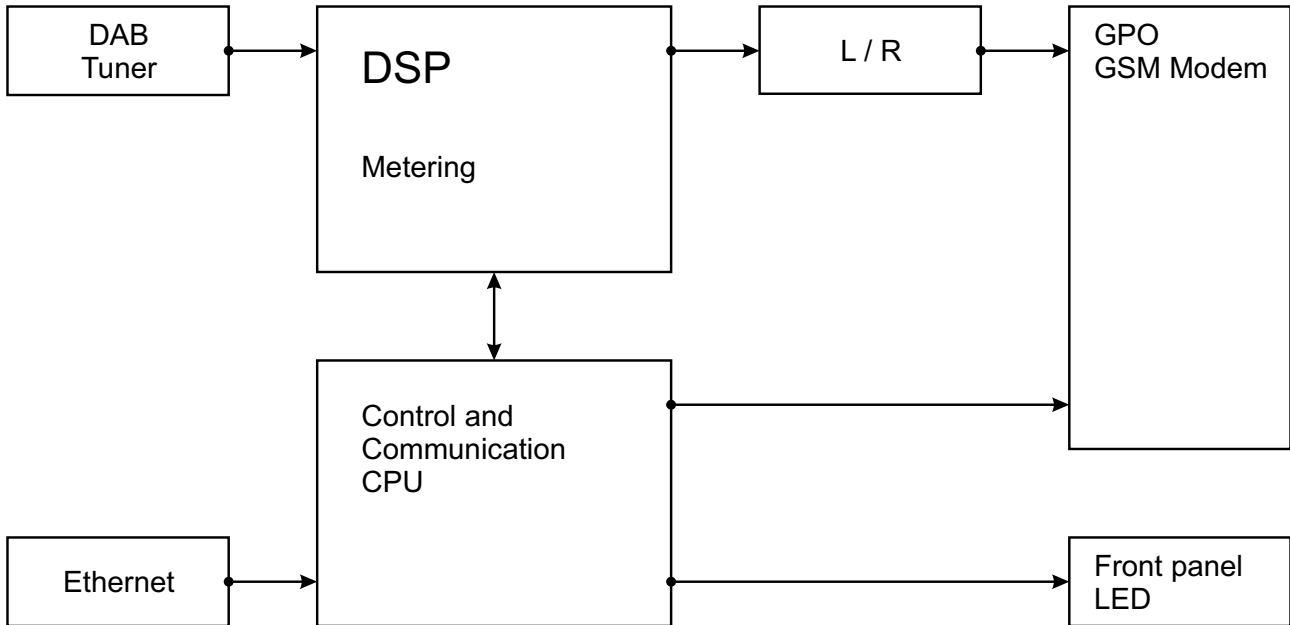

Because of the all-digital, minimalist-discrete-component nature of device circuitry, we have not provided schematic diagrams of the DB7012 in this Manual. Please, note that:

**NO USER-SERVICEABLE COMPONENTS INSIDE.
REFER ALL SERVICING TO
QUALIFIED TECHNICAL PERSONNEL.**

Safety Warning

ALWAYS OBSERVE THE SAFETY PRECAUTIONS.

Careful observance of the safety precautions will help prevent physical injury, damage of the equipment, and extend the equipment life.

- The servicing of electronic equipment should be performed only by qualified personnel;
- Before removing the covers the unit must be switched off and the mains cable unplugged;
- When the equipment is open, the power supply capacitors should be discharged using a suitable resistor;
- Never touch the wires or the electrical circuits;
- Use insulated tools only;
- Never touch the metal semiconductor. They might carry high voltages;
- For removing and installing electronic components, follow the recommendations for handling MOS components.
- Do not remove the factory sticker from the equipment. It contains information as regards the name, serial number and MAC address of the device.
- To join the equipment to the mains supply, use the power cord purchased with the equipment.

ATTENTION: The device has an internal Lithium battery. Do not try to re-charge this battery! In case the battery needs to be changed, please contact us for detailed instructions and information of the battery type.

Panel Indicators, Switches and Connectors



INDICATORS

POWER – indicates that the device is powered up and working.

RF LOSS – will be indicated whenever the level of the RF signal of the Main Station drops below the selected threshold.

AUDIO LOSS – will be indicated whenever the level of the Left and Right audio channels drops below the selected threshold.

ALARM – will be lit if an alarm event is detected.

OLED DISPLAY

DB7012 has easy to read, high-resolution OLED graphical display that visualizes all measurements of the received signal and DB7012's settings.

LED METERS

The full-time LED meters allow quick and easy monitoring of the metering, making the setup, adjustment and programming easy.

CONTEXT-SENSITIVE SOFT BUTTONS

Used for navigation through the menus, quick access to the parameters, modes, functions and to alter their values. The soft buttons indicators are placed on the bottom side of the OLED display. Depending on the currently selected menu context the indicators change their function. The soft buttons will be referred as (left-to-right) [SB1], [SB2], [SB3] and [SB4].

NAVIGATIONAL BUTTONS

[UP], [DOWN], [LEFT], [RIGHT] and [OK] buttons, are used to navigate through the menus selecting various functions and parameters of DB7012.

REAR PANEL

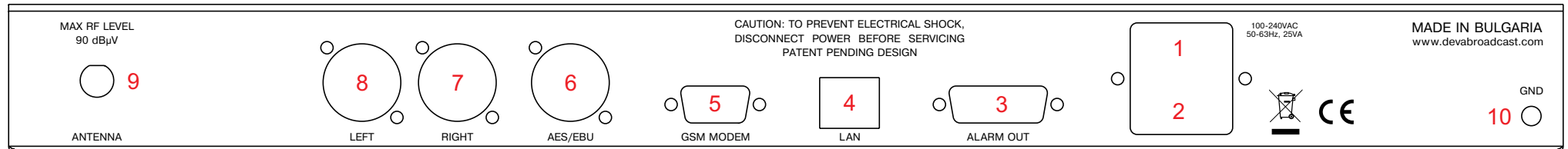

1. Mains connector, 110-240VAC, IEC-320 C14 type;
2. Fuse holder;
3. GPO – Opto-isolated, Female D-Sub 15 pins.
4. Ethernet T-BASE10/100 RJ45;
5. GSM Modem – Male D-Sub 15 pins High Density;
6. Audio AES/EBU Output - XLR;
7. Audio Right Output - XLR;
8. Audio Left Output - XLR;
9. RF Input (Antenna) - BNC;
10. GND Pin - Chassis Earth Ground;

REAR PANEL ALARM TERMINAL

BEFORE ELECTRICAL SHOCK,
TURN OFF POWER BEFORE SERVICING
FOR THE LATEST DESIGN

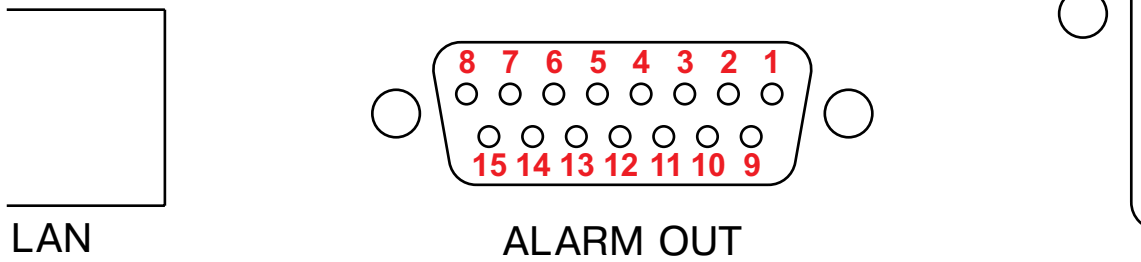

- | | |
|--------------------|-------------------|
| 1 - GPO1 Collector | 9 - GPO1 Emitter |
| 2 - GPO2 Collector | 10 - GPO2 Emitter |
| 3 - GPO3 Collector | 11 - GPO3 Emitter |
| 4 - GPO4 Collector | 12 - GPO4 Emitter |
| 5 - GPO5 Collector | 13 - GPO5 Emitter |
| 6 - GPO6 Collector | 14 - GPO6 Emitter |
| 7 - GPO7 Collector | 15 - GPO7 Emitter |
| 8 - GND | |

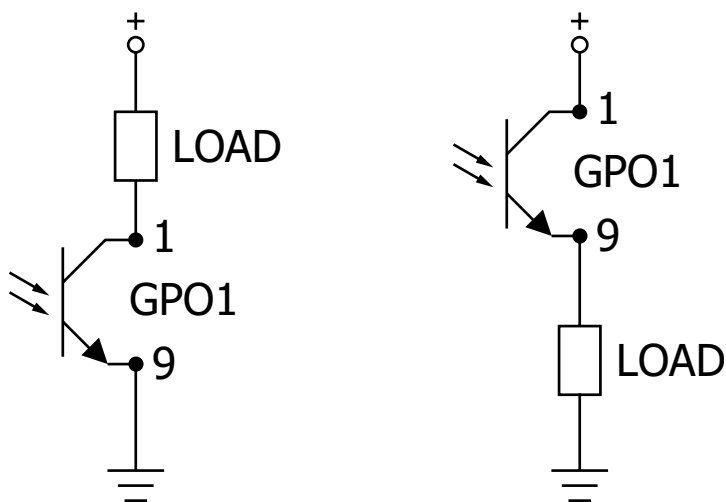

Operating Recommendations

To ensure normal operation of the DEVA unit, we recommend following the instructions listed below.

- Install the unit in places with good air conditioning. The unit is designed to operate within the ambient temperature range of 10 to 50°C. The equipment rack should be ventilated in order for the device to keep its internal temperature below the maximum ambient temperatures;
- We do not recommend installation in rooms with high humidity, dusty places or other aggressive conditions;
- Although the device is intended to be installed closed to exciters or transmitters, we do recommend the device to be located away from abnormally high RF fields.
- Use only checked power supply cables. We strongly recommend the usage of shielded cables;
- Connect the DEVA unit to reliable power supply sources only. In case of unstable power supply, please use Uninterruptible Power Supply (UPS);
- Use the device only with its top cover on to avoid electromagnetic anomalies. Otherwise, this may cause problems with the normal functionality of the unit;
- To ensure normal remote operation of the unit, make sure to connect the device to a good quality Internet connection;
- For the normal operation of your DEVA device, check if the network settings past through all the required data traffic.

Unpacking and inspection

Upon receipt, the equipment should be inspected for possible shipping damages. If such are found or suspected, notify the carrier at once and contact DEVA Broadcast Ltd. The original shipping carton box and packing materials should be kept for possible reuse, in case of return for Warranty repair, for example. Shipping damages as a result of improper packing for return may invalidate the Warranty!

The packing material (plastic bags, polystyrene, nails, etc.) must never be left within reach of children, as these items are potential sources of danger.

IT IS VERY IMPORTANT that the [“Product Registration Card”](#) included in the Manual be completed accurately and returned. This will assure coverage of the terms of the Warranty and it will provide a means of trace in case of lost or stolen equipment. In addition, the user will automatically receive SERVICE OR MODIFICATION INSTRUCTIONS from DEVA Broadcast Ltd.

Mounting

RACK REQUIREMENTS 1U

The unit mounts in a standard 19-inch equipment rack and requires only 1 $\frac{3}{4}$ inches (1U) of vertical rack space. In order the painted finish around the mounting holes to be protected, the use of plastic washers is recommended.

RACK REQUIREMENTS COMPACT UNITS

Our customized 1U 19-inch rack accessory provides a professional mounting option for up to three compact size DEVA units. It is made of milled aluminum and finished in black powder coat. Two extra blanking panels and set of mounting screws are provided with each rack bracket kit.

STAND-ALONE DEVICES

DEVA's stand-alone units (Radio Explorer series, BandScanner series, DVB Explorer) do not require additional tools or installation brackets.

AC Mains Power

FUSE HOLDER

The fuse holder is placed inside the unit, next to the voltage selector. Apply downward pressure and pull the cap outward to access the 5mm mains fuse. The reverse process will release the cap.

MAINS VOLTAGE SELECTOR

Before connecting the AC Power, make sure that the internal Power Switch is in accordance with the mains supply at your location. The Power Supply Factory Settings are:

- 100 - 240 VAC
- 1 Amp Fuse

CAUTION: Permanent damage will result if improper AC supply voltage is applied to the device. The warranty DOES NOT cover damages caused by applying improper supply voltage or usage of improper fuse.

POWER CORD

The detachable IEC-type power cord is supplied with the unit. The individual cord conductors may be color-coded in either of two ways:

1) In accordance with US standards:
BLACK = AC "HOT"
WHITE = AC NEUTRAL
GREEN = EARTH GROUND

2) To European CEE standards:
BROWN = AC "HOT"
BLUE = AC NEUTRAL
GREEN/YELLOW = EARTH GROUND

GROUND LOOPS

Because the unbalanced INPUTS/OUTPUTS of the device are chassis-ground-referenced, a mains frequency or INPUT/OUTPUT ground loop could be formed between the input or output cable shield grounds and the AC power cord ground. A 'ground-lifting' AC adapter may help in this situation, although the chassis must be properly grounded for safety purposes. In general, the equipment being installed in a rack will satisfy the safety requirement.

Getting Started

In order for the normal operation of the DB7012 to be guaranteed, you will need fulfill the following conditions:

1. Standard Ethernet 10/100M connection;
2. Correctly assigned Network configuration and device settings.

To make sure that all the conditions are fulfilled please, follow the instructions below.

CONNECTION

1. Install the unit on its operation place;
2. Using the provided power cable, connect the unit to the power supply network;
3. Connect the antenna cable to the RF antenna input connector located on the rear panel of the device;
4. Connect the DB7012 to the TCP/IP network using direct network cable;
5. **IF GSM OPTION IS SUPPORTED** - Using the connection cable provided, connect the optional GSM modem. In order for better GSM network coverage to be achieved, please select proper place for the GSM antenna.

NOTE: The GSM antenna must be installed far enough from the monitoring devices. The GSM modem radiates RF signal that may cause spurious emissions that will may interfere with the accuracy of the measurements. For detailed explanation of the option, please refer to [“GSM Modem Option” on page 55](#).

NETWORK SETTINGS

After connecting the network cable the Led 'LAN' located on the rear panel must be ON or flashing. The next and most important step for configuration is the adjustment procedure of the Network Communication. The settings shown below are Default Network Settings:

DHCP	Enabled
IP	Assigned by DHCP
Mask	Assigned by DHCP
Gateway	Assigned by DHCP
DNS	Assigned by DHCP
HTTP Port	80

NETWORK DISCOVERY

This is a network setting that defines whether your computer can see (find) other computers and devices on the network and whether other computers on the network can see your computer. By default, Windows Firewall blocks network discovery but you can enable it.

1. Open Advanced sharing settings by clicking the Start button, and then on "Control Panel". In the search box, type "network", click "Network and Sharing Center", and then, in the left pane click "Change advanced sharing settings";
2. Select your current network profile;
3. Click "Turn on network discovery", and then click save changes.

NOTE: If you're prompted for an administrator password or confirmation, type the password, provide confirmation or contact your system administrator.

If you have already enabled this function on your computer DB7012 will be automatically added to the Device list section. The device will be ready for usage and no additional adjustments will be required except user name and password.

NOTE: If the port is different than the default one (80), it is necessary to specify it, for example:
`http://192.168.1.2:9000`

ATTENTION: Depending on Internet Protocol Settings, the assigned IP address may not be visible outside your local network, thus the device may be accessed only within that network. Consult with your network administrator for the appropriate IP settings.

NETWORK SECURITY RECOMMENDATIONS

1. It is not recommended the DB7012 to be directly connected to the Internet. This may lead to unregulated access and/or problematic operation of the device. To ensure secure connection, we recommend the device to be installed behind a router with an active firewall.
2. If remote access to the device is needed, we recommend using VPN to the router or the port of the relevant service (WEB, SNMP, Application, etc.) to be properly NAT forwarded.
3. If NAT forward is used, it is highly recommended random ports of your choice to be used. Not the standard ones (80 for WEB, 161 for SNMP, etc.).
4. Using DMZ connection is not recommended.
5. Make sure to change the standard access credentials (usernames and passwords, SNMP communities).

For detailed information as regards the recommendations listed above or need of further instructions, please contact your network administrator.

Basic Setup

OLED DISPLAY

DB7012 has an easy to read, high-resolution OLED graphical display that visualizes all measurements of the received signal and settings. Upon switching it on, the Company Logo and model of the device will be displayed. After a few seconds the start-up screen will disappear, replaced by the main screen. This is the starting point of the navigation process.

DB7012's OLED display has three function areas: header, soft buttons and main screen working area.

HOW TO CHANGE DEVICE PARAMETERS

Set-up menu title

Shows the path to the currently selected menu. Note that the parameter should be included in the settings menu title. For example: *Setup> Communication> HTTP> Port* is different from *Setup> Communication> FTP> Data Port*.

Navigation area

Selection of branches / parameters is made in this area. The selected item is highlighted. All parameters are listed on the left side of the navigational area. All parameter values are displayed on the right side against the parameter name. As the branches have no values associated, tree dots are shown instead. This indicates that a transition to a sub-menu is available.

Front panel buttons usage:

[OK] – Depending on the selected menu element can perform different actions:

- Menu branch – transition to selected sub-menu will be made;
- Menu parameter – when a name of a parameter is highlighted pressing [OK] will highlight the value and switch to edit mode;
- Menu complex parameter (such as *Alarm*) – the parameter editor screen will be shown.

[UP] / [DOWN] – If edit mode is active, the value of the selected parameter will be changed.

Otherwise, are used for navigation through the menu;

[LEFT] / [RIGHT] – Change the selection when the parameter value is in edit mode;

[SB4] – Return one level up or cancel edit mode.

There are several parameter types available in DB7012. The way of editing depends of the parameter type. Every parameter type has its own editing rules.

Numerical parameter

Represents numerical value.

Example: The value *Frequency* can be changed in the range of **87.10 MHz** to **108.10 MHz** and *Frequency Step* of **10 kHz**, **20 kHz**, **50 kHz** or **100 kHz**.

Front panel buttons usage:

[UP] / [DOWN] – Change the value of the parameter with one step. The step value may vary depending on the selected parameter. The value always stays in permitted parameter range;

[OK] – Accept the changed value and exit edit mode;

[SB4] – will discard the value and cancel edit mode.

Enumerated parameter

Represent the selection of a value among set of predefined enumerated values.

Example: The value *Attenuator* can be selected from **Auto**, **OFF**, **-10dB**, **-20dB** and **-30dB**.

Front panel buttons usage:

[UP] / [DOWN] – Cycle through the possible values;

[OK] – Accept the changed value and exit edit mode;

[SB4] – will discard the value and cancel edit mode.

IP address

Represents an IPv4 address.

Example: **Primary DNS** 192.168.001.001 , **Network Mask** 255.255.255.000

Front panel buttons usage:

[LEFT] / [RIGHT] – Select edit marker position;

[UP] / [DOWN] – Cycle through the possible values;

[OK] – Accept the changed value and exit edit mode;

[SB4] – Discards all changes and cancels edit mode.

IP port

Represents TCP or UDP port.

Example: **Manager Port** 162

Front panel buttons usage: Refer to IP address.

Date

Represent date from the calendar.

Example: **Date** 15-Jun-2012

Front panel buttons usage:

[LEFT] / [RIGHT] – Selects previous/next segment from the date;

[UP] / [DOWN] – Cycle through the possible values;

[OK] – Accept the changed value and exit edit mode;

[SB4] – Discards all changes and cancels edit mode.

Time

Represent time information.

Example: **Time** 02:00:00

Front panel buttons usage: Refer to Date.

Timer

Represents relative time interval.

Example: **Screen Saver** **2 min**

Front panel buttons usage:

[UP] / [DOWN] – Increments/decrements value with one step. The unit value will be changed automatically from seconds to minutes and vice-versa;

[OK] – Accept the changed value and exit edit mode;

[SB4] – Discards all changes and cancels edit mode.

String

Represents string.

Example: **User Name** **user**

Front panel buttons usage:

[LEFT] / [RIGHT] – Select edit marker position. If [RIGHT] button is pressed when the marker is at the last character, a space character will be added at the end of the string. When the [LEFT] button is pressed all trailing spaces will be removed;

[UP] / [DOWN] – Cycle through the possible values. Depending on the string context there is a limitation in the permitted char set. For example phone number string can contain only 1234567890+ and blank space characters;

[OK] – Accept the changed value and exit edit mode. Some strings, like e-mail addresses, must pass a validation check. If the validation fails, message box will appear. Press [OK] to dismiss the message. Note that edit mode will not be left. For example:



If [OK] is pressed



If [OK] is pressed



[Insert] – Inserts blank space before the selected character:

User Name us| – before

User Name us| – after

[Delete] – Deletes the selected character:

User Name us| – before

User Name us| – after

[Cancel] – Discards all changes and cancels edit mode.

HOME SCREEN

The home screen contains all the needed information as regards the signal received. The header is located on the left part of the screen. The header content is determined according to the work area context and may include the functions described below.



1. Parameter FIC quality (0 to 100%)
2. Audio transmit mode
3. Channel mode – Mono, Stereo, Dual channels. The graphic indicator will change depending on the channel mode.
4. Speakers volume indicator (0 to 100%)
5. Channel number
6. Channel frequency (in MHz)
7. Indicates the current service chosen, and the number of services available
8. Indicates whether the device is in DAB or DAB+ mode
9. Indicates the audio codec in use
10. Service name
11. Bit Rate and Sample Rate
12. Ensemble name
13. Date and Time – transmitted by DAB/DAB+
14. Indicates whether there is multimedia object transport (MOT) at the current service
15. Genre
16. DLS

The soft buttons [SB1], [SB2] and [SB3] could be assigned with quick access presets. [SB4] opens a menu containing the full preset list and controls to edit presets.



The [UP] and [DOWN] buttons will visualize list with all available services. The [LEFT] and [RIGHT] buttons change the current service - previous or next. The currently selected service will be indicated with PLAY symbol in front of the name.



MAIN SCREEN WORKING AREA



The main part of the OLED screen is where the data changes dynamically, depending on the selected operating mode. The *Menu* screen (shown above) appears upon pressing of the [OK] button. DB7012's *Menu* page contains selectable icons and soft buttons for selecting modes and functions. Pressing [LEFT] and [RIGHT] arrow buttons will change the icon selection on the *Menu* page. The current selection is shown as a rectangle focus frame around the icon. Pressing [OK] button will navigate to the corresponding page.

SOFT BUTTONS

Used for navigation through the menus, quick access to the parameters, modes, functions and to alter their values. The soft buttons indicators are placed on the bottom side of the OLED display.

Depending on the currently selected menu context, the indicators change their function. The soft buttons will be referred to as (left-to-right) [SB1], [SB2], [SB3] and [SB4]. The purpose of all soft button corresponds to the selected menu page. Most pages have the same or similar functional areas. The corresponding functions as Menu page, parameter to be changed, etc., linked with the soft buttons will appear as labels above them. For example:

- [SB1] – *Home*
- [SB2] – *About*
- [SB3] – Unused
- [SB4] – *Back*

NOTE: On some pages, the header and soft button area will disappear in order to expose the content underneath.

NAVIGATION BUTTONS

[UP], [DOWN], [LEFT], [RIGHT] and [OK] buttons are used to navigate through the menus, for selecting various functions and parameters of DB7012. The main menu structure has an up-and-down basis, expanded with left-to-right branches.

MENU PAGES



TUNER

This menu allows you to change the DAB Channel and apply changes to the currently selected DAB/DAB+.

OUTPUT

The settings applied through this menu have influence on the audio level of the analog and digital outputs.



SETUP

Enter the main *Menu* page, select Setup icon and press [OK].



The *Setup* menu is organized into a hierarchical tree menu and all similar parameters are grouped into sections (branches). The structure of the menu is:

- **Communication** – grants you access to the *General Setup* (to enable or disable the functions included in the menu), **Ethernet**, **SNMP**, **HTTP**, **FTP**, **SNTP** and **Email**.
- **Security** – From here you could set-up, change or disable the password protected access to the *Front Panel* or *Remote access*.
- **Device** – allows you to change the name of the device, set-up the *Date/Time*, change the default settings of the OLED graphical display (menu *Front panel*), change the *Home Screen*, specify the *Weblog Max Days*, average and peak values and finally to return the device to its *Factory Defaults*. *Country Region* allows you to specify the region in which the device will be used - Europe, USA and Japan. The RDS standard utilized will be changed accordingly.

SECURITY

Keyboard lock

To prevent unauthorized local access, the DB7012 offers password protected keyboard locking. By default the keyboard is unprotected. To enable this function, using the front panel navigational menu, go to *Setup> Security> Front Panel*, then press [OK] and **Enable** the *Access Control* function. Set the preferred 5 digit password and *Access Timeout*. Once the keyboard lock function is enabled, every attempt to use it will require a password:

ENTER PASSWORD: 0****. Access will be denied upon false entry.

Keyboard unlock

If the keyboard unlock function has been activated by mistake, try to unlock it using the default password **01234**. In order to deactivate the code protection, once the front panel menu is unlocked follow the menu path *Setup> Security> Front Panel> Access Control* and then select **Disabled**. If you do not manage to unlock the front panel with the default password, nevertheless whether it has been changed intentionally or not, DB7012 should be returned to its factory defaults in order for the password security to be disabled.

NOTE: The password consists of 5 digits. The leading zeroes are not shown in the menu, but should be specified when entering the unlock password. For example, if your password is 123, when entering the password 00123 should be written.

MONITORING

This menu pages allow you configure Logger Services. There is submenu page for each Channel containing Service Settings. For more information of Logger and Services please refer to [“Logger” on page 45](#) and [“Logger Service Settings” on page 46](#).



Alarms is a special parameter type with its own dialog editor. Each alarm parameter is composed of the following sub-parameters:

- **Alarm Low threshold** – the lower alarm limit of the measured signal. If the value stays below this limit for predefined time “low alarm” event will be generated;
- **Alarm High threshold** – the higher alarm limit of the measured signal. If the value stays above this limit for predefined time “high alarm” event will be generated;
- **Warning Low threshold** – the lower warning limit of the measured signal. If the value stays below this limit for predefined time “warning low” event will be generated;
- **Warning High threshold** – the higher warning limit of the measured signal. If the value stays above this limit for predefined time “warning high” event will be generated;
- **Trigger time** – waiting time before a “low alarm” or “high alarm” event is generated;
- **Release time** – waiting time before an “Idle alarm” event is generated;
- **Set of notification channels** – In case of alarm, maintenance staff will be immediately alerted via E-mail, SNMP or GPO, which allows technicians to restore the normal service as soon as possible.

Alarms set-up – Option 1

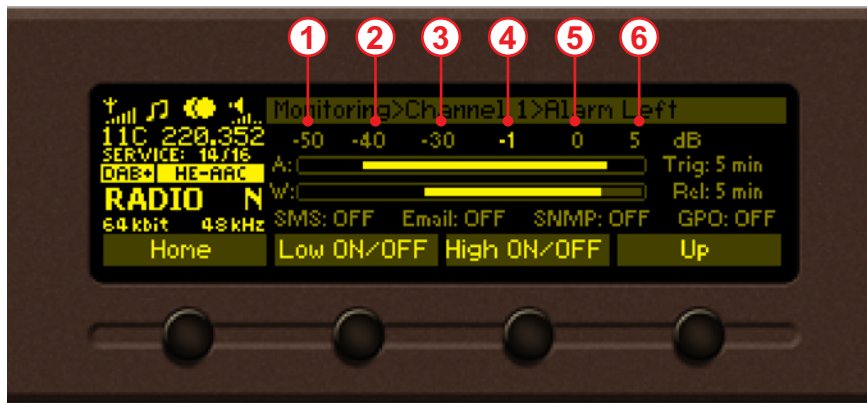

The bar graph indicates the signal range of the alarm. The highlighted area represents the permitted signal value range. If current signal value is in this range, no alarm event will be generated. Basic elements of the alarm editor dialog:

- | | |
|------------------------------------|-------------------------------------|
| 1. Lower Limit of the alarm range; | 4. Warning High threshold value; |
| 2. Alarm Low threshold value; | 5. Alarm High threshold value; |
| 3. Warning Low threshold value; | 6. Higher limit of the alarm range. |

Alarms set-up – Option 2



The basic elements of the alarm editor dialog are:

1. Alarm turned ON/OFF;
2. Trigger time (default value is set to 20 seconds);
3. Release time (default value is set to 26 seconds).

Alarm edit dialog, front panel buttons usage:

[LEFT] / [RIGHT] – Selects previous/next sub-parameter of the alarm.

[UP] / [DOWN] – Change the value of the selected (highlighted) sub-parameter. The value always stays in the permitted parameter range. Low threshold value cannot exceed the high threshold and vice-versa;

[OK] – Accept the value and exits edit dialog;

[SB2] – Toggles ON/OFF the low alarm generation;

[SB3] – Toggles ON/OFF the high alarm event generation;

[SB4] – Discards all changes and cancels edit mode.

Buttons [SB2] “Low On/Off” and [SB3] “High On/Off” toggle the state of the corresponding Alarm and Warning limits, ex.:

- Both Alarm Low and Warning Low limits are Off;
- Alarm Low limit is On, Warning Low limit if Off;
- Alarm Low limit is Off, Warning Low limit if On;
- Both Alarm Low and Warning Low limits are On.

STATUS

The basic/general information on the device is found here:

- Device – Model, Serial number, Firmware version in use, Calibration, Storage capacity;
- IP address – IP, Network Mask, Gateway, Primary DNS, Secondary DNS;



WEB Interface menu pages

DEVICE CONTROL INTERFACE

The WEB Interface is visually divided into two sections Left and Right.

- On the Right are the specific contextual readings of the currently selected menu page.
- On the Left is the so called “dashboard” of the device - General Tuner and Channel readings, functional buttons. This section of the WEB interface is constant part of each screen, hence allowing immediate tuner interactions.

DB7012 “dashboard” content:

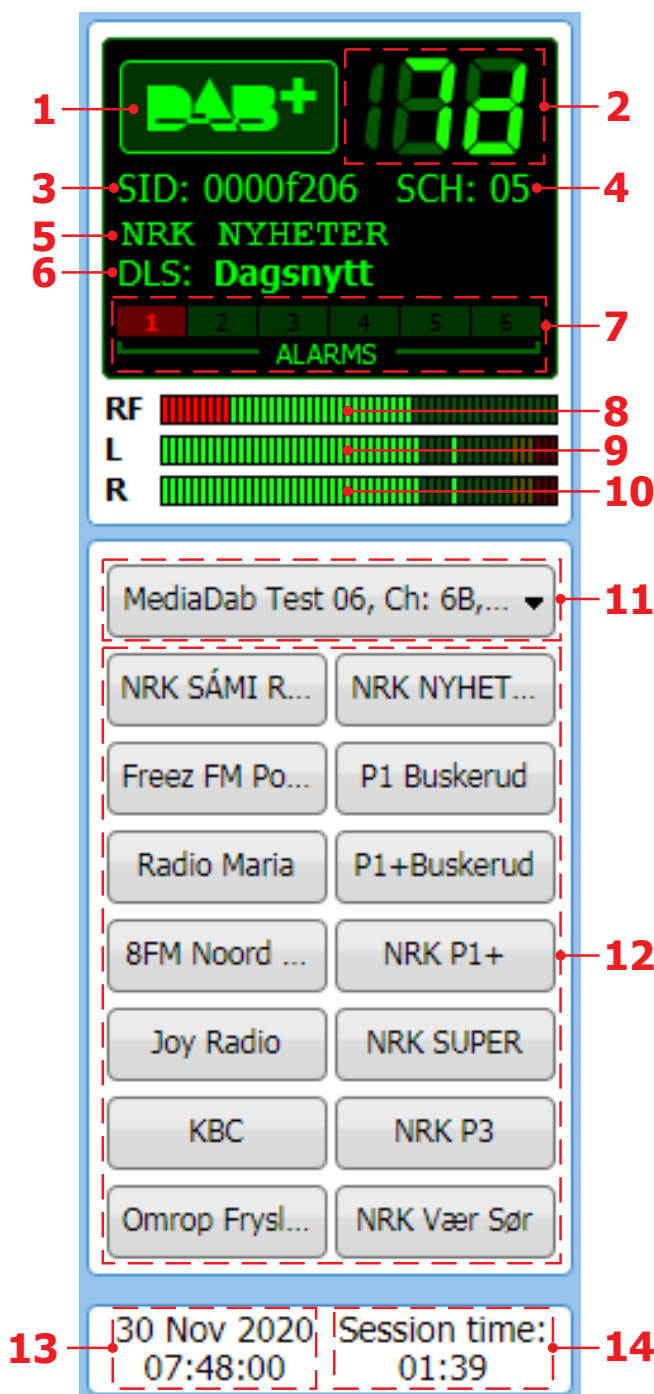

1. DAB+ Logo
2. Frequency indicator showing currently tuned frequency;
3. SID – This 16-bit field shall specify the DAB Service Identifier (SID) to which the information block data applies;
4. SCH – Sub Channel ID;
5. Currently selected service label;
6. DLS – (Dynamic Label Segment) scrolling text;
7. Alarm presence indicator – will be lit in red when an alarm on at least one channel is detected;
8. RF Level indicator. The red zone (low level) indicates low RF level;
9. Left Audio indicator;
10. Right Audio indicator;
11. Drop-down Select Service menu;
12. Service Preset Buttons – when one of the buttons is pressed, the Tuner will be set to the predefined service.
13. Device Time and Date;
14. Session time;

Drop-down Select Service menu options:

A list containing all services available in the current Ensemble.

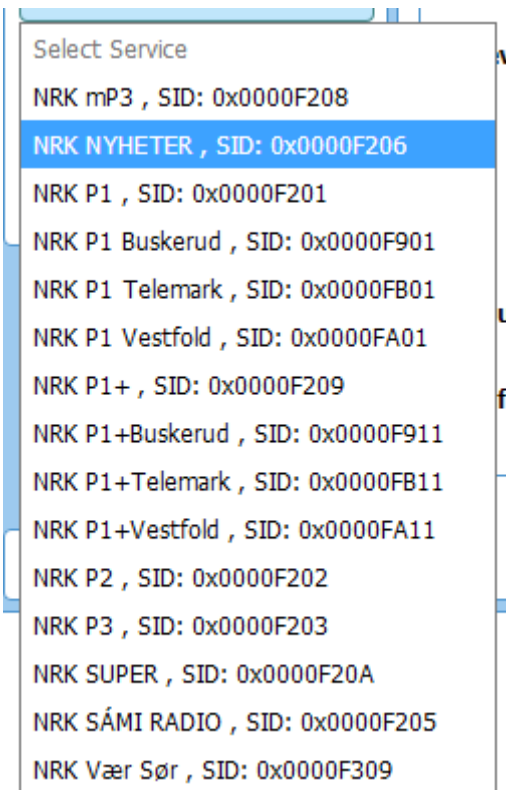

MAIN

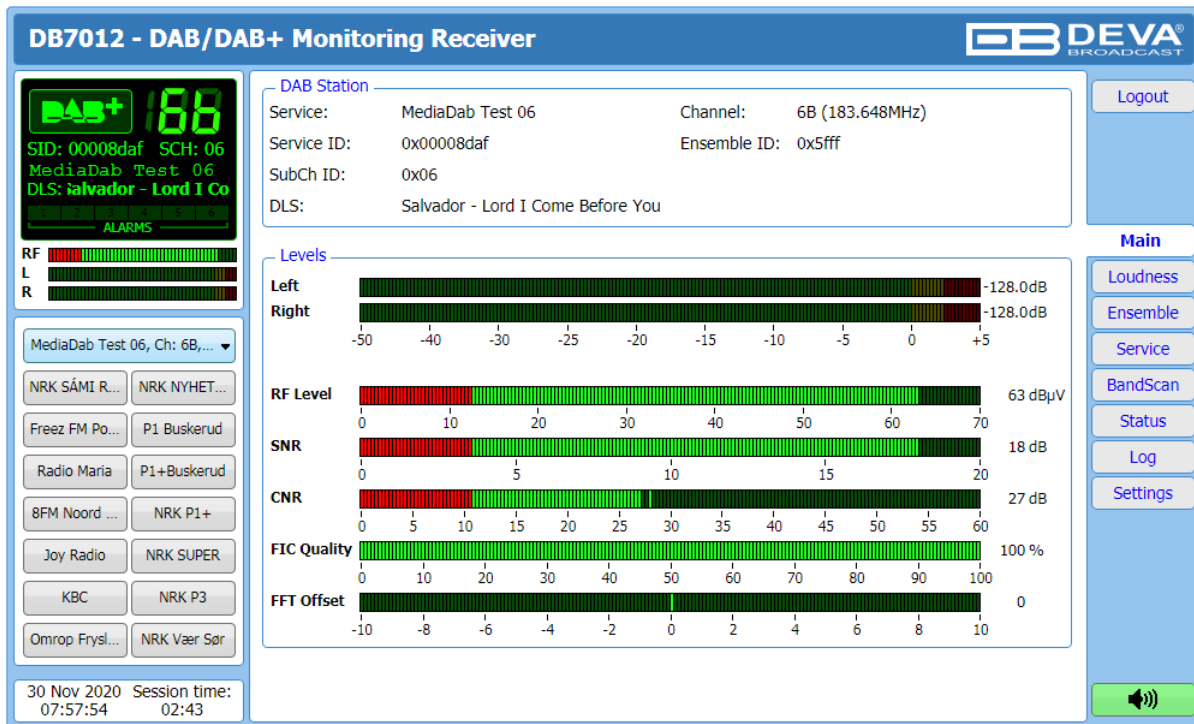

The Main Screen of the WEB Interface shows all the mandatory parameters represented as LED readings and the current DAB station status (DAB Station).

Using the selection buttons, placed on the left part of the screen, you can easily select the preferred audio frequency. All station presets are user defined.

[Listen] button – used to Play/Stop the current audio stream (audio device will be required).

LOUDNESS

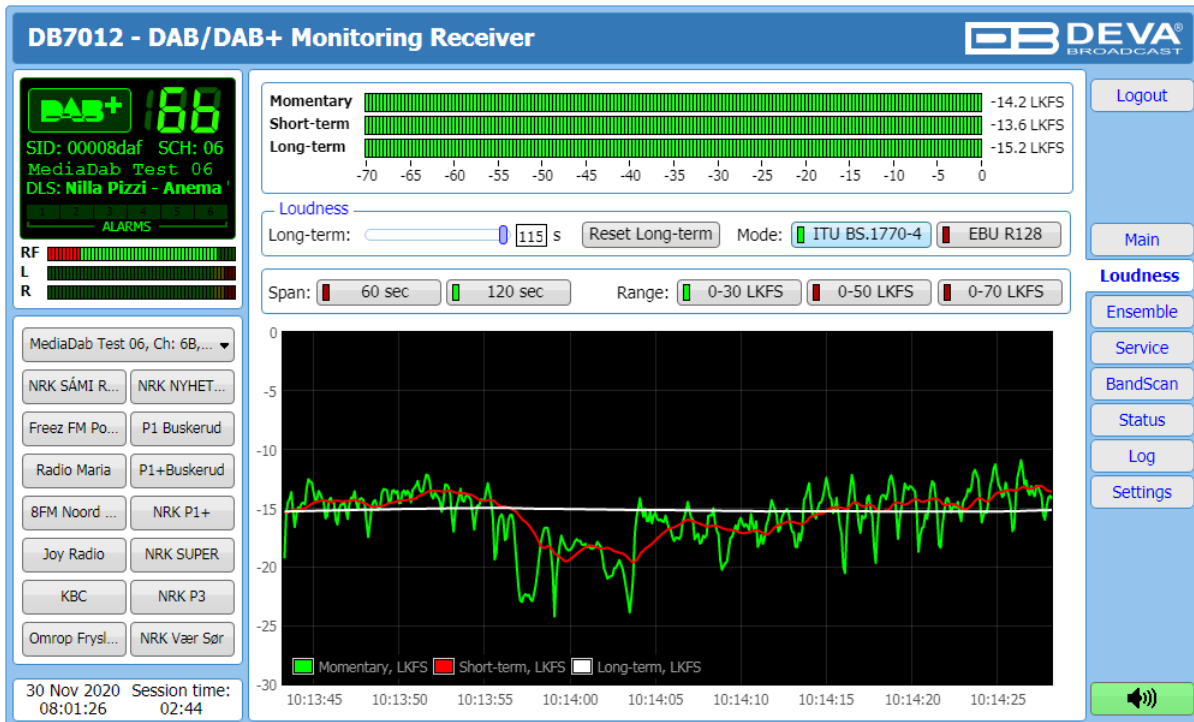

The average program loudness measurements as defined by the ITU BS.1770-4 and EBU R128 recommendations are represented in this page. The following measurements are available:

- **Momentary** – average program loudness measured over a 0.4 seconds sliding time window, not gated;
- **Short-term** – average program loudness measured over a 3 seconds sliding time window, not gated;
- **Long-term** – average program loudness measured over a variable sliding time window, gated as described in ITU BS.1770-4. The time window can be varied between 10 seconds and 120 seconds.

The page offers all the above measurements in two display forms – high refresh rate bar graphs for displaying current values and a time graph for extended visualization over time.

The user can modify the processing and appearance of the measurement using the following settings:

- **Long-term** – allows the user to select the length of the Long-term loudness measurement sliding time window. The time-based sliding window could be set with length from 10 to 120 seconds;
- **[Reset Long-term]** – resets the Long-term measurement;
- **Mode** – select between [ITU BS.1770-4] and [EBU R128] mode;
- **Span** – [60 sec] and [120 sec] are available;
- **Range** – the option buttons allow the user to set the preferred time graph measurement range.

ENSEMBLE

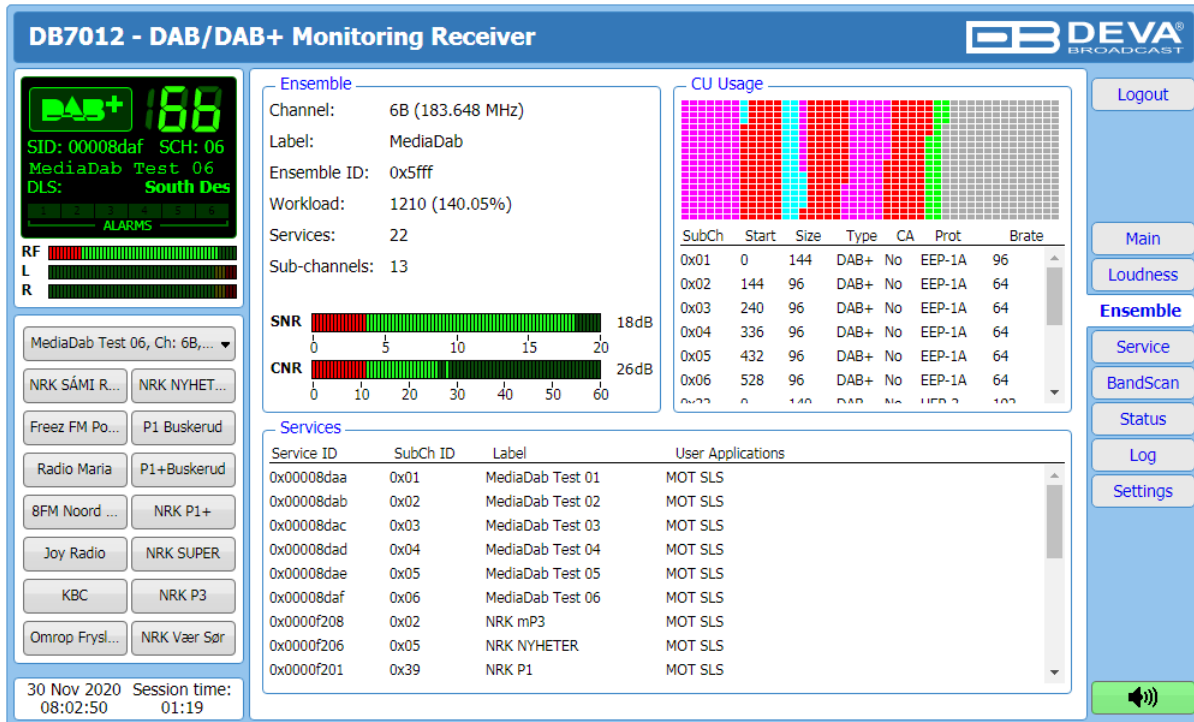

Ensemble

Channel: 6B (183.648 MHz)
 Label: MediaDab
 Ensemble ID: 0x5fff
 Workload: 1210 (140.05%)
 Services: 22
 Sub-channels: 13

SNR: 18dB
 CNR: 26dB

SubCh	Start	Size	Type	CA	Prot	Brate
0x01	0	144	DAB+	No	EEP-1A	96
0x02	144	96	DAB+	No	EEP-1A	64
0x03	240	96	DAB+	No	EEP-1A	64
0x04	336	96	DAB+	No	EEP-1A	64
0x05	432	96	DAB+	No	EEP-1A	64
0x06	528	96	DAB+	No	EEP-1A	64

Service ID	SubCh ID	Label	User Applications
0x00008daa	0x01	MediaDab Test 01	MOT SLS
0x00008dab	0x02	MediaDab Test 02	MOT SLS
0x00008dac	0x03	MediaDab Test 03	MOT SLS
0x00008dad	0x04	MediaDab Test 04	MOT SLS
0x00008dae	0x05	MediaDab Test 05	MOT SLS
0x00008daf	0x06	MediaDab Test 06	MOT SLS
0x0000f208	0x02	NRK mP3	MOT SLS
0x0000f206	0x05	NRK NYHETER	MOT SLS
0x0000f201	0x39	NRK P1	MOT SLS

Ensemble

This section provides information about the currently selected ensemble - Channel, Label, Ensemble ID, Workload, number of available Services and Sub-channels. NR (signal-to-noise) and CNR (carrier-to-noise) indicators in dB, represented as LED readings, are also available.

CU usage





Visual representation of the CU usage of the Ensemble is available in this section of the WEB Interface. An ensemble has a maximum bit rate that can be carried. It depends on the used error protection level. Usually all DAB multiplexes can carry a total of 864 “capacity units”. Having said that the number of capacity units (or CU) that a certain bit-rate level requires, depends on the amount of error correction added to the transmission.

Services

An Ensemble will typically carry multiple services from multiple radio networks. List of the available Services can be found in this tab.

SERVICE

DB7012 - DAB/DAB+ Monitoring Receiver

 188
 SID: 00008daf SCH: 06
 MediaDab Test 06
 DLS: Jon Banfield, Can
 ALARMS
 RF 
 L 
 R 

MediaDab Test 06, Ch: 6B,...

NRK SÁMI R...	NRK NYHET...
Freez FM Po...	P1 Buskerud
Radio Maria	P1+Buskerud
8FM Noord ...	NRK P1+
Joy Radio	NRK SUPER
KBC	NRK P3
Omrop Frysl...	NRK Vær Sør

30 Nov 2020 Session time:
08:03:59 00:11

Service

DLS:	Jon Banfield, Candy Apple - No1 - Jihad Muhammad Remix		
Label:	MediaDab Test 06	SID:	0x8daf
PTY:	Pop Music	SubCh ID:	0x06
CU Start:	528	SubCh BitRate:	64 kbps
CU Count:	96	CU Level:	96
DAB Mode:	DAB+	DAB TM:	MSC Stream Audio
Serv. Mode:	DAB+	Prot. Info:	EEP-1A
Audio Mode:	HE-AAC	Audio Chan:	Stereo
Audio SRate:	48 kHz	Audio BitRate:	64 kbps

Slideshow



Logout

Main

Loudness

Ensemble

Service

BandScan

Status

Log

Settings

🔊

This page contains information on all the mandatory parameters of the currently selected service. Slideshow is also displayed (if available).

BAND SCAN

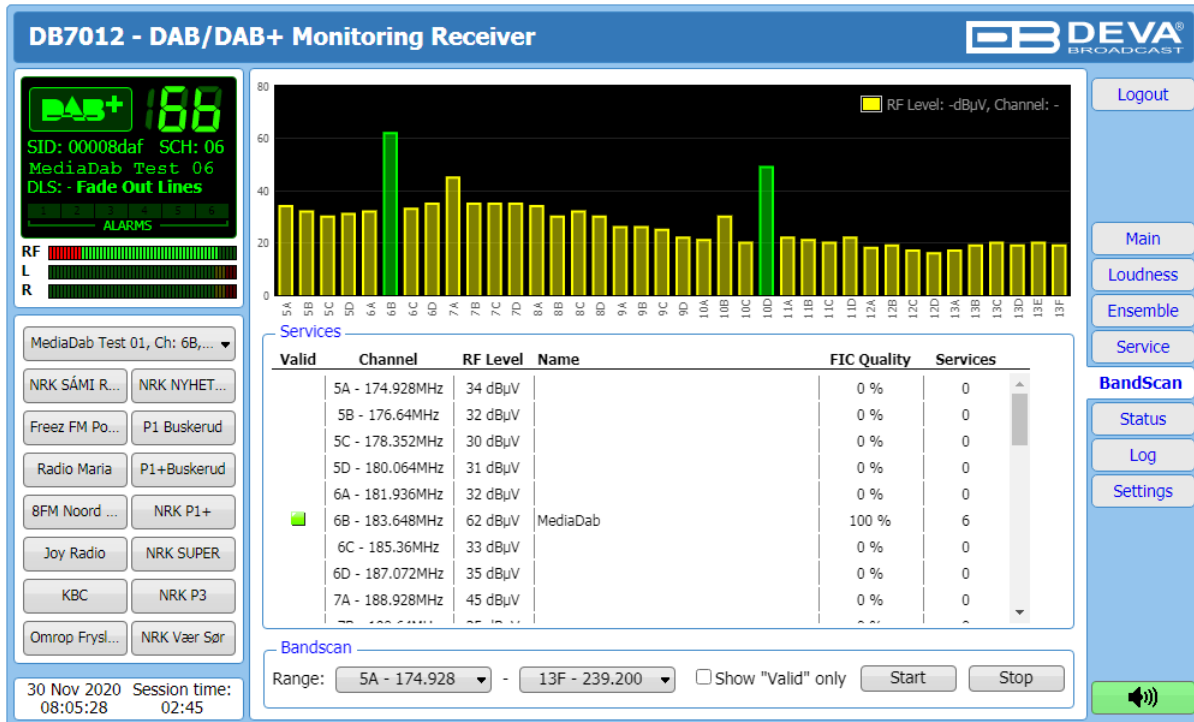

The bandscanning mode is easily customized by setting range of the scan. To start a bandscan follow the instructions listed below:

1. Set the bandscan range;
2. Specified whether all results or the Valid only will be shown;
3. Press the [Start] button;
4. The scan can be stopped at any point by pressing the [Stop] button.

All valid results will be illuminated in green. When Valid only is selected, the services list will look like this:

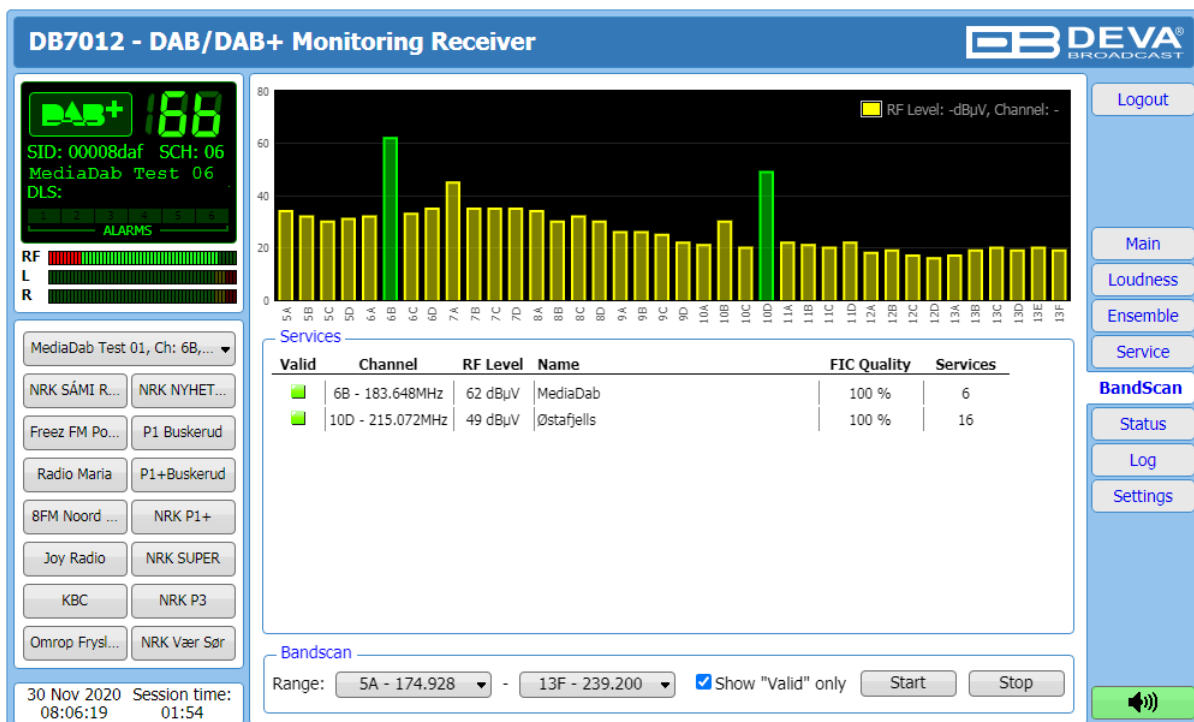

STATUS

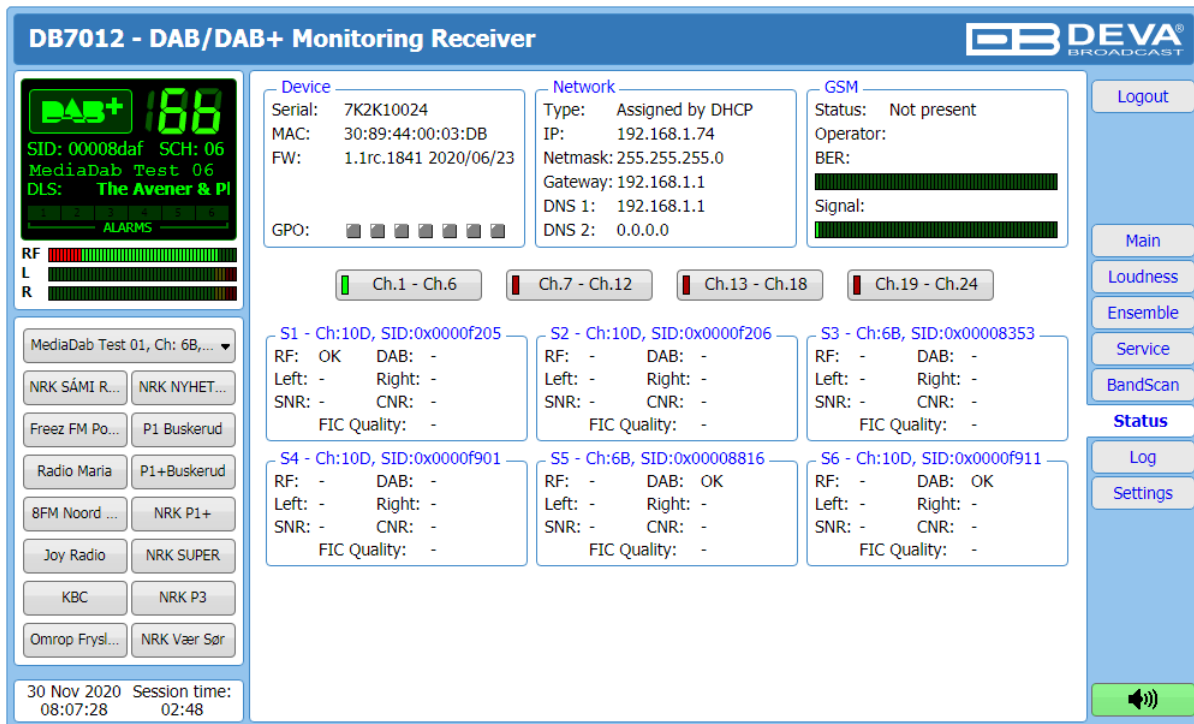

DB7012 - DAB/DAB+ Monitoring Receiver

Device
 Serial: 7K2K10024
 MAC: 30:89:44:00:03:DB
 FW: 1.1rc.1841 2020/06/23
 GPO: [Progress Bar]

Network
 Type: Assigned by DHCP
 IP: 192.168.1.74
 Netmask: 255.255.255.0
 Gateway: 192.168.1.1
 DNS 1: 192.168.1.1
 DNS 2: 0.0.0.0

GSM
 Status: Not present
 Operator:
 BER: [Progress Bar]
 Signal: [Progress Bar]

Channels:
 Ch.1 - Ch.6 (Green)
 Ch.7 - Ch.12 (Red)
 Ch.13 - Ch.18 (Red)
 Ch.19 - Ch.24 (Red)

Services:

Service	RF	DAB	Left	Right	SNR	CNR	FIC Quality
S1 - Ch:10D, SID:0x0000f205	OK	-	-	-	-	-	-
S2 - Ch:10D, SID:0x0000f206	-	-	-	-	-	-	-
S3 - Ch:6B, SID:0x00008353	-	-	-	-	-	-	-
S4 - Ch:10D, SID:0x0000f901	-	-	-	-	-	-	-
S5 - Ch:6B, SID:0x00008816	-	OK	-	-	-	-	-
S6 - Ch:10D, SID:0x0000f911	-	OK	-	-	-	-	-

30 Nov 2020 08:07:28 Session time: 02:48

The status tab shows the alarm status of each parameter of the preset frequencies, along with the basic device and network status (IP address, MAC, etc.). If a GSM modem is connected, the status of the modem will also be depicted in the relevant section.

The Service parameters (RF, SNR, CNR etc.) have several conditions:

- In range – green OK;
- Out of range – red LOW, HIGH or LOSS;
- Signal monitoring is not enabled – n/a.

LOG

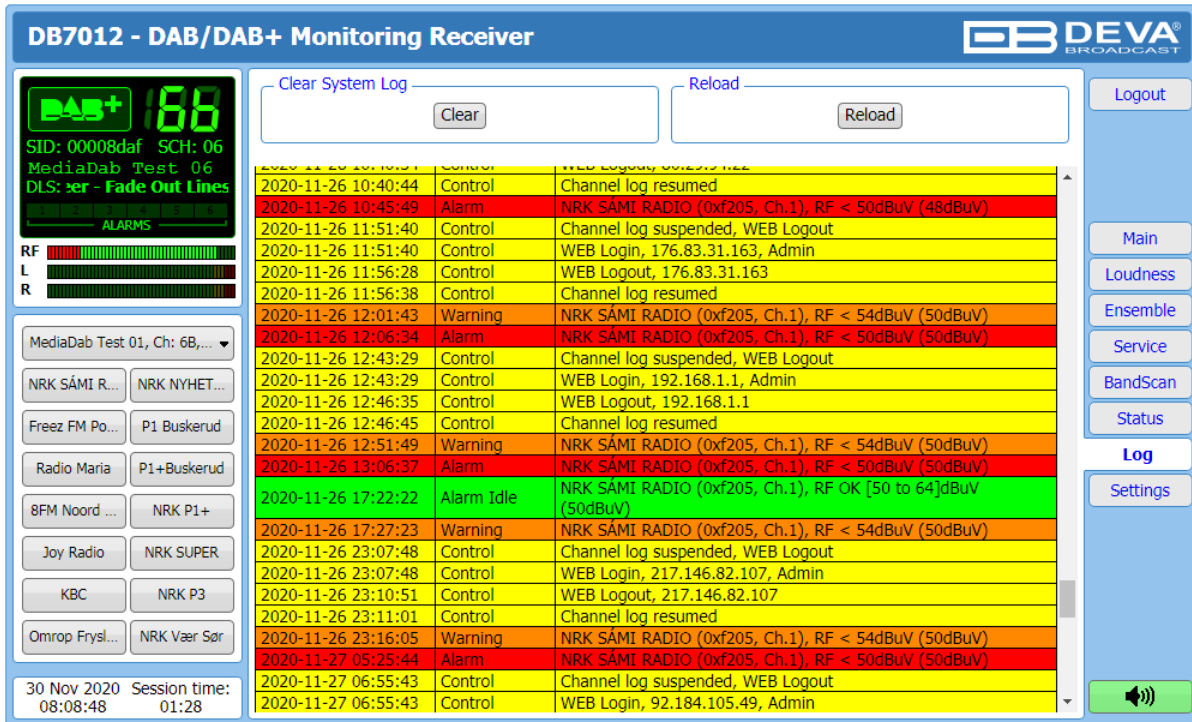

The screenshot shows the 'DB7012 - DAB/DAB+ Monitoring Receiver' interface. At the top left, there's a status display showing 'SID: 00008daf SCH: 06', 'MediaDab Test 06', and 'DLS: ær - Fade Out Lines'. Below this are RF signal strength indicators for L and R channels. A central panel contains a list of system events with columns for date/time, status, and description. On the right side, there are navigation buttons: Logout, Main, Loudness, Ensemble, Service, BandScan, Status, Log (highlighted), and Settings. At the bottom left, session information is displayed: '30 Nov 2020 08:08:48' and 'Session time: 01:28'.

Date/Time	Status	Description
2020-11-26 10:40:44	Control	Channel log resumed
2020-11-26 10:45:49	Alarm	NRK SÁMI RADIO (0xf205, Ch.1), RF < 50dBuV (48dBuV)
2020-11-26 11:51:40	Control	Channel log suspended, WEB Logout
2020-11-26 11:51:40	Control	WEB Login, 176.83.31.163, Admin
2020-11-26 11:56:28	Control	WEB Logout, 176.83.31.163
2020-11-26 11:56:38	Control	Channel log resumed
2020-11-26 12:01:43	Warning	NRK SÁMI RADIO (0xf205, Ch.1), RF < 54dBuV (50dBuV)
2020-11-26 12:06:34	Alarm	NRK SÁMI RADIO (0xf205, Ch.1), RF < 50dBuV (50dBuV)
2020-11-26 12:43:29	Control	Channel log suspended, WEB Logout
2020-11-26 12:43:29	Control	WEB Login, 192.168.1.1, Admin
2020-11-26 12:46:35	Control	WEB Logout, 192.168.1.1
2020-11-26 12:46:45	Control	Channel log resumed
2020-11-26 12:51:49	Warning	NRK SÁMI RADIO (0xf205, Ch.1), RF < 54dBuV (50dBuV)
2020-11-26 13:06:37	Alarm	NRK SÁMI RADIO (0xf205, Ch.1), RF < 50dBuV (50dBuV)
2020-11-26 17:22:22	Alarm Idle	NRK SÁMI RADIO (0xf205, Ch.1), RF OK [50 to 64]dBuV (50dBuV)
2020-11-26 17:27:23	Warning	NRK SÁMI RADIO (0xf205, Ch.1), RF < 54dBuV (50dBuV)
2020-11-26 23:07:48	Control	Channel log suspended, WEB Logout
2020-11-26 23:07:48	Control	WEB Login, 217.146.82.107, Admin
2020-11-26 23:10:51	Control	WEB Logout, 217.146.82.107
2020-11-26 23:11:01	Control	Channel log resumed
2020-11-26 23:16:05	Warning	NRK SÁMI RADIO (0xf205, Ch.1), RF < 54dBuV (50dBuV)
2020-11-27 05:25:44	Alarm	NRK SÁMI RADIO (0xf205, Ch.1), RF < 50dBuV (50dBuV)
2020-11-27 06:55:43	Control	Channel log suspended, WEB Logout
2020-11-27 06:55:43	Control	WEB Login, 92.184.105.49, Admin

Here are listed all the Device System Events. The local measurements and logs are saved in the internal device memory. All log files can be downloaded via the built-in FTP server. For information on how the connection between the DB7012 and an FTP Client should be configured, please refer to [“Download files via FTP” on page 60.](#)

[Clear] will delete the System log.

[Reload] will refresh the information.

GENERAL SETTINGS

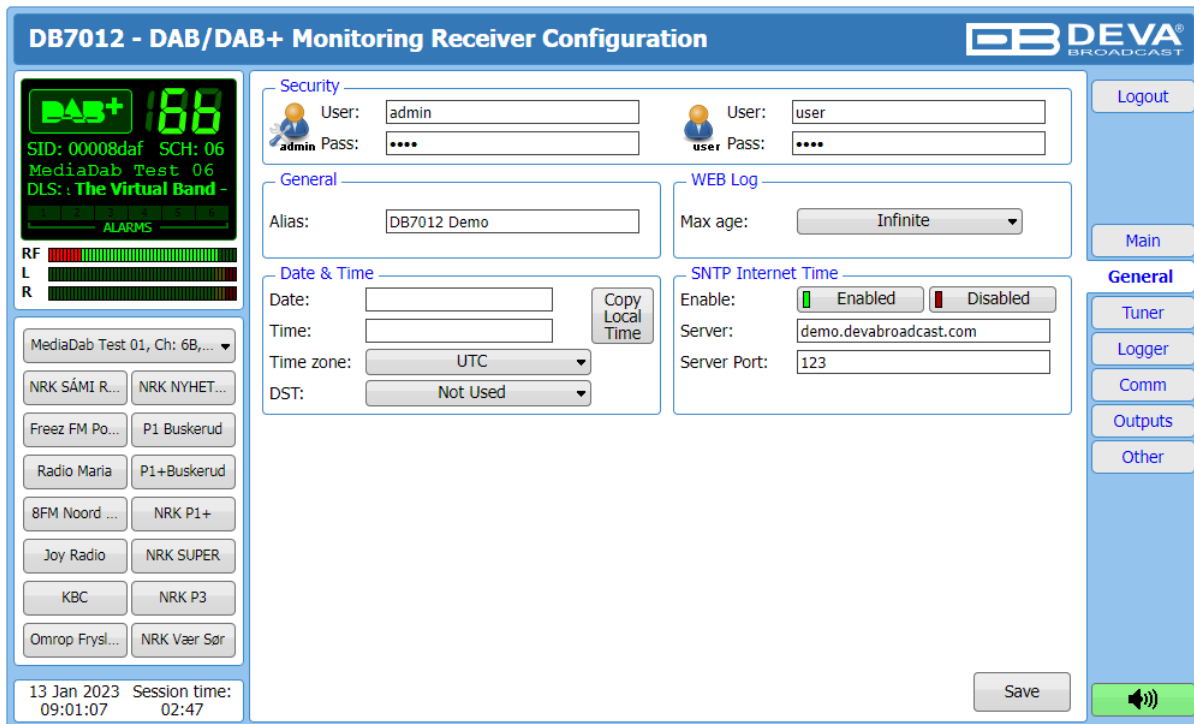

DB7012 provides you with protected access to the device settings. You can choose between two types of log in.

- As an Administrator – It will give you full control over the settings of the device;
- As a User – that will allow you to just monitor the device and to choose different stations, while the Settings bar remains locked.

In order for the security of DB7012 to be enhanced, a new **username** and **password** could be set from the Security section. By choice, you can change the name of the device (General section). Later on, it will be used as a title name for all WEB pages. Customizing the name will make the device more recognizable.

WEB Log – the maximum storage time of the System Log file is chosen from here. If the file is older than the specified maximum will be deleted.

Date & Time – used for manually set the current Date and Time. [Copy Local Time] button will set the Date and Time to correspond to that of your computer.

SNTP Internet Time – Synchronizes automatically the DB7012 clock to a millisecond with the Internet time server. Enable this function in order to use it. (Specifying the server closest to your location will improve the accuracy).

NOTE: In order for the applied settings to be used press the [Save] button, placed on the bottom right part of the screen.



TUNER SETTINGS

DB7012 - DAB/DAB+ Monitoring Receiver Configuration

 188



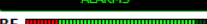

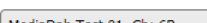
SID: 00008daf SCH: 06
 MediaDab Test 06
 DLS: and - Material Girl





ALARMS





RF 
 L 
 R 





MediaDab Test 01, Ch: 6B, ...





NRK SÁMI R... NRK NYHET...
 Freez FM Po... P1 Buskerud
 Radio Maria P1+Buskerud
 8FM Noord ... NRK P1+
 Joy Radio NRK SUPER
 KBC NRK P3
 Omrop Frysl... NRK Vær Sør





DAB Channel
 5A:  5A - 174.928MHz
 5B:  5B - 176.640MHz
 5C:  5C - 178.352MHz
 5D:  5D - 180.064MHz





DAB Channel
 6A:  6A - 181.936MHz
 6B:  6B - 183.648MHz
 6C:  6C - 185.360MHz
 6D:  6D - 187.072MHz





DAB Channel
 7A:  7A - 188.928MHz
 7B:  7B - 190.640MHz
 7C:  7C - 192.352MHz
 7D:  7D - 194.064MHz







DAB Channel
 8A:  8A - 195.936MHz
 8B:  8B - 197.648MHz
 8C:  8C - 199.360MHz
 8D:  8D - 201.072MHz

DAB Channel
 9A:  9A - 202.928MHz
 9B:  9B - 204.640MHz
 9C:  9C - 206.352MHz
 9D:  9D - 208.064MHz

DAB Channel
 10A:  10A - 209.936MHz
 10B:  10B - 211.648MHz
 10C:  10C - 213.360MHz
 10D:  10D - 215.072MHz

DAB Channel
 11A:  11A - 216.928MHz
 11B:  11B - 218.640MHz
 11C:  11C - 220.352MHz
 11D:  11D - 222.064MHz

DAB Channel
 12A:  12A - 223.936MHz
 12B:  12B - 225.648MHz
 12C:  12C - 227.360MHz
 12D:  12D - 229.072MHz

DAB Channel
 13A:  13A - 230.784MHz
 13B:  13B - 232.496MHz
 13C:  13C - 234.208MHz
 13D:  13D - 235.776MHz
 13E:  13E - 237.488MHz
 13F:  13F - 239.200MHz

Available Services

Service	Channel	SID	SubCh ID
<input type="radio"/> MediaDab Test 01	6B	0x00008DAA	0x01
<input type="radio"/> MediaDab Test 02	6B	0x00008DAB	0x02
<input type="radio"/> MediaDab Test 03	6B	0x00008DAC	0x03
<input type="radio"/> MediaDab Test 04	6B	0x00008DAD	0x04
<input type="radio"/> MediaDab Test 05	6B	0x00008DAE	0x05
<input checked="" type="radio"/> MediaDab Test 06	6B	0x00008DAF	0x06
<input type="radio"/> NRK mP3	10D	0x0000F208	0x02
<input type="radio"/> NRK NYHETER	10D	0x0000F206	0x05
<input type="radio"/> NRK P1	10D	0x0000F201	0x39
<input type="radio"/> NRK P1 Buskerud	10D	0x0000F901	0x39
<input type="radio"/> NRK P1 Telemark	10D	0x0000FB01	0x3a
<input type="radio"/> NRK P1 Vestfold	10D	0x0000FA01	0x3b
<input type="radio"/> NRK P1+	10D	0x0000F209	0x39

30 Nov 2020 Session time:
 08:10:59 02:41

Save 

The Tuner Section gives control over Tuner settings, allowing you to select a DAB channel and service. All available services will be listed below once the list is collected from the multiplex data.

LOGGER

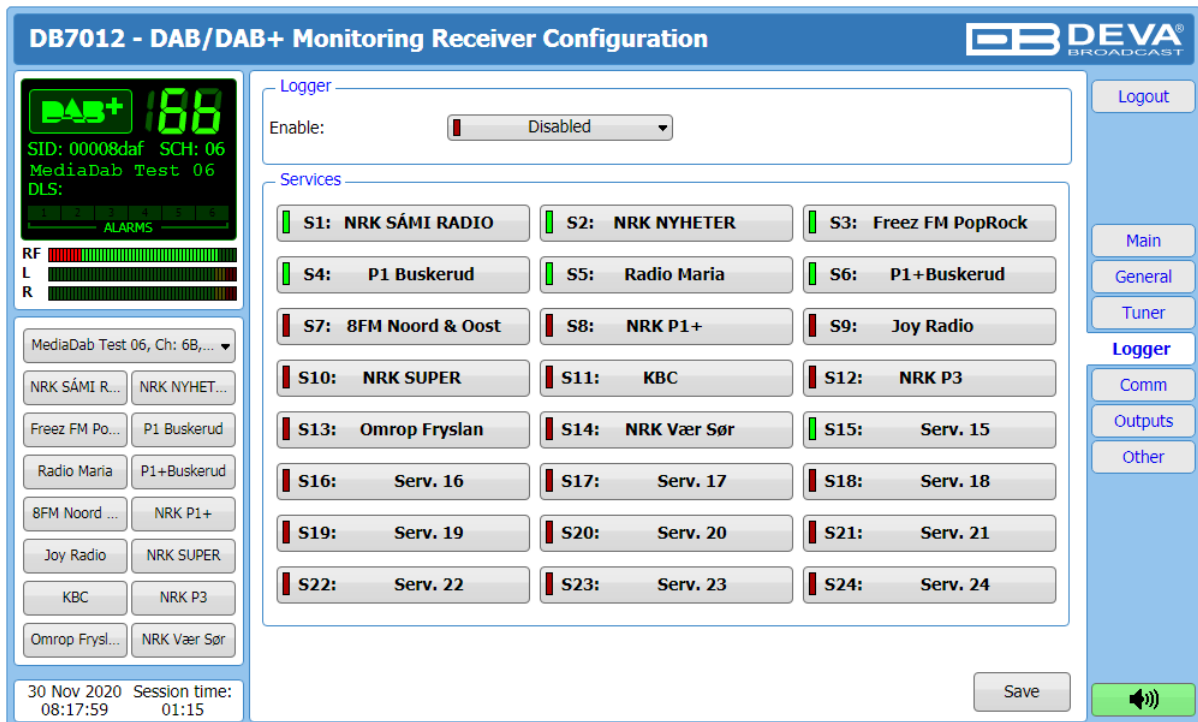

The DB7012 can monitor up to 24 preset DAB Services at regular intervals and send alarm notification via E-mail, SMS, SNMP and GPO. Each preset has its own configuration page that contains a group of settings used for monitoring and alerting.

All of the collected information is accessible through the built-in FTP Server. ([see “Download files via FTP” on page 60](#))

Follow the steps below to initiate the simplified process of starting a Logger mode:

- Set the Logger’s start time delay;
- Click on a service to open the settings page;
- Set the Name and Frequency parameters for each of the channels;
- Set the Acquisition time for each service;
- In order for a service to be included in the campaign, the “Enable”/”Disable” button should be selected. To exclude a station from the campaign select the “Disable” button.

LOGGER SERVICE SETTINGS (SERVICE 1)

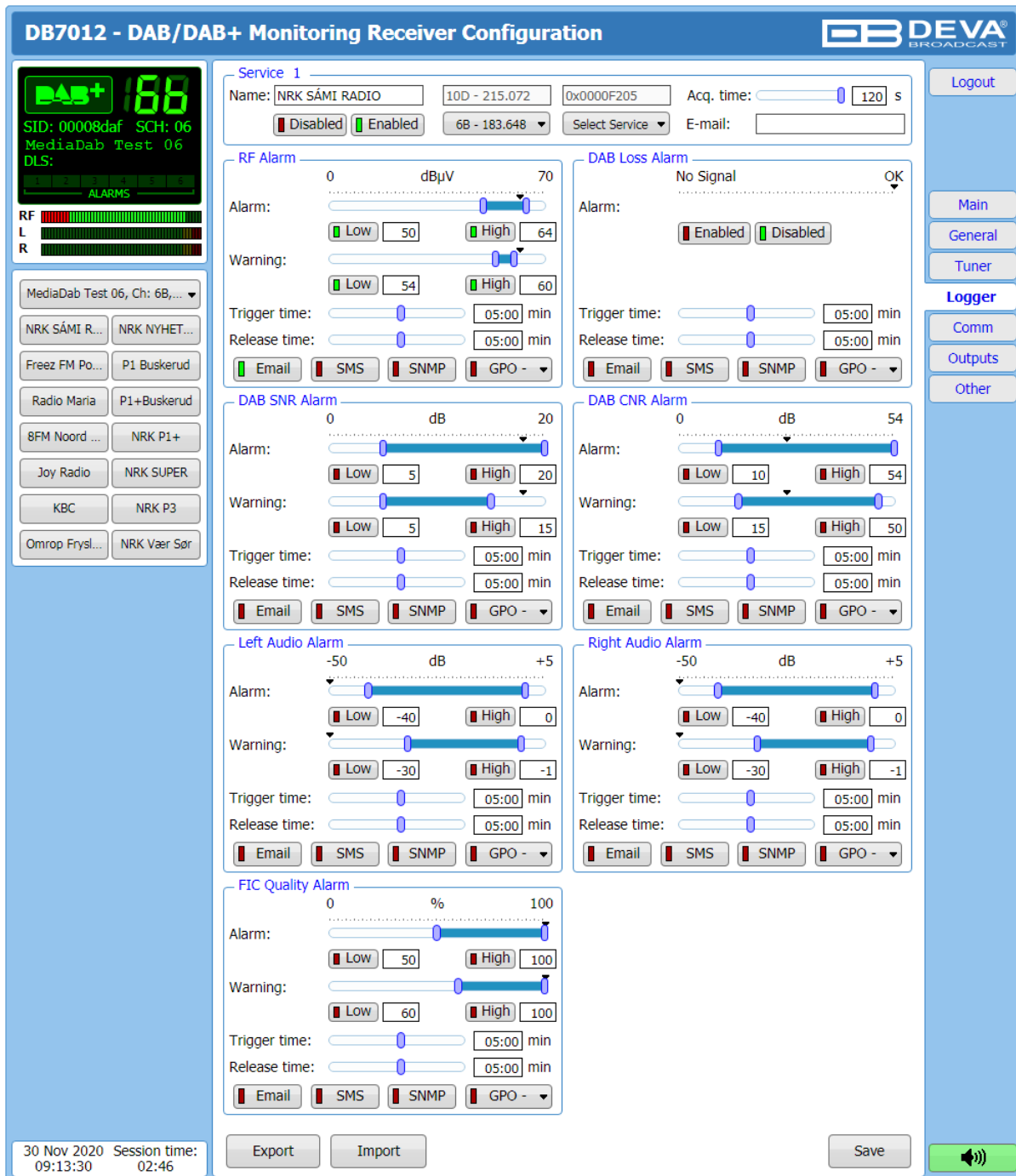

DB7012 - DAB/DAB+ Monitoring Receiver Configuration

Service 1

Name: NRK SÁMI RADIO | 10D - 215.072 | 0x0000F205 | Acq. time: 120 s

Disabled Enabled | 6B - 183.648 | Select Service | E-mail: _____

RF Alarm (0 to 70 dB μ V)

Alarm: | Low: 50 | High: 64

Warning: | Low: 54 | High: 60

Trigger time: 05:00 min | Release time: 05:00 min

Email SMS SNMP GPO

DAB Loss Alarm (No Signal)

Alarm: Enabled Disabled

Trigger time: 05:00 min | Release time: 05:00 min

Email SMS SNMP GPO

DAB SNR Alarm (0 to 20 dB)

Alarm: | Low: 5 | High: 20

Warning: | Low: 5 | High: 15

Trigger time: 05:00 min | Release time: 05:00 min

Email SMS SNMP GPO

DAB CNR Alarm (0 to 54 dB)

Alarm: | Low: 10 | High: 54

Warning: | Low: 15 | High: 50

Trigger time: 05:00 min | Release time: 05:00 min

Email SMS SNMP GPO

Left Audio Alarm (-50 to +5 dB)

Alarm: | Low: -40 | High: 0

Warning: | Low: -30 | High: -1

Trigger time: 05:00 min | Release time: 05:00 min

Email SMS SNMP GPO

Right Audio Alarm (-50 to +5 dB)

Alarm: | Low: -40 | High: 0

Warning: | Low: -30 | High: -1

Trigger time: 05:00 min | Release time: 05:00 min

Email SMS SNMP GPO

FIC Quality Alarm (0 to 100 %)

Alarm: | Low: 50 | High: 100

Warning: | Low: 60 | High: 100

Trigger time: 05:00 min | Release time: 05:00 min

Email SMS SNMP GPO

30 Nov 2020 Session time: 09:13:30 02:46

Export Import Save

Measurement windows can be set for each of the DAB services: RF, Left and Right audio levels, DAB Loss, DAB SNR, DAB CNR, FIC quality. Trigger and alarm release times can be set for each alarm.

Please bear in mind that the type of alarm notification (Email, SMS, SNMP, GPO) is set for each parameter individually. To enable the preferred notification method, press the relevant button so that it could be illuminated in green.

Service

- Name – preset alias. The same name will appear on the quick access buttons in the “dashboard”;
- [Enabled]/[Disabled] channel monitoring and sending of warnings and alarms. If the channel is not generally enabled, the frequency will not be monitored and alarm notifications will not be received;
- Service – select the desired service from the drop-down menu;
- Acquisition time – specify the observation time for the current station (before switching to the next channel);
- E-mail – set email address that will receive alarm notifications for this service only.

Alarm

- Alarm Range – interactive slider used to adjust the Low & High thresholds at which an alarm will be generated;
- Warning Range – interactive slider used to adjust the Low & High thresholds at which a warning will be generated;
- Threshold – buttons to enable/disable alarm range limits;
- Trigger Time – waiting time before Active Alarm/Warning is generated;
- Release Time – waiting time before Idle Alarm/Warning is generated;
- Alarm notification option.

IMPORTANT NOTE: Warnings and Alarms are generated only when the Logger mode is running. While there is any user interaction, alarm will not be generated and send. The Logger starts running once the user logs out of the WEB interface.

Trigger and Release times define the time, which should elapse in order for the received signal to be defined as low/high/lost or restored/OK. What we recommend is the release time to be bigger than the trigger time.

NOTE: When setting Trigger and Release times, have in mind that 01:00 means 1 minute, and 00:01 means 1 second.

NOTE: In order for the applied settings to be used press the [Save] button, placed on the bottom right part of the screen.

[Export] will export the currently applied alarms settings.

[Import] allows you to import the Service settings from other DB7012.

COMMUNICATION SETTINGS

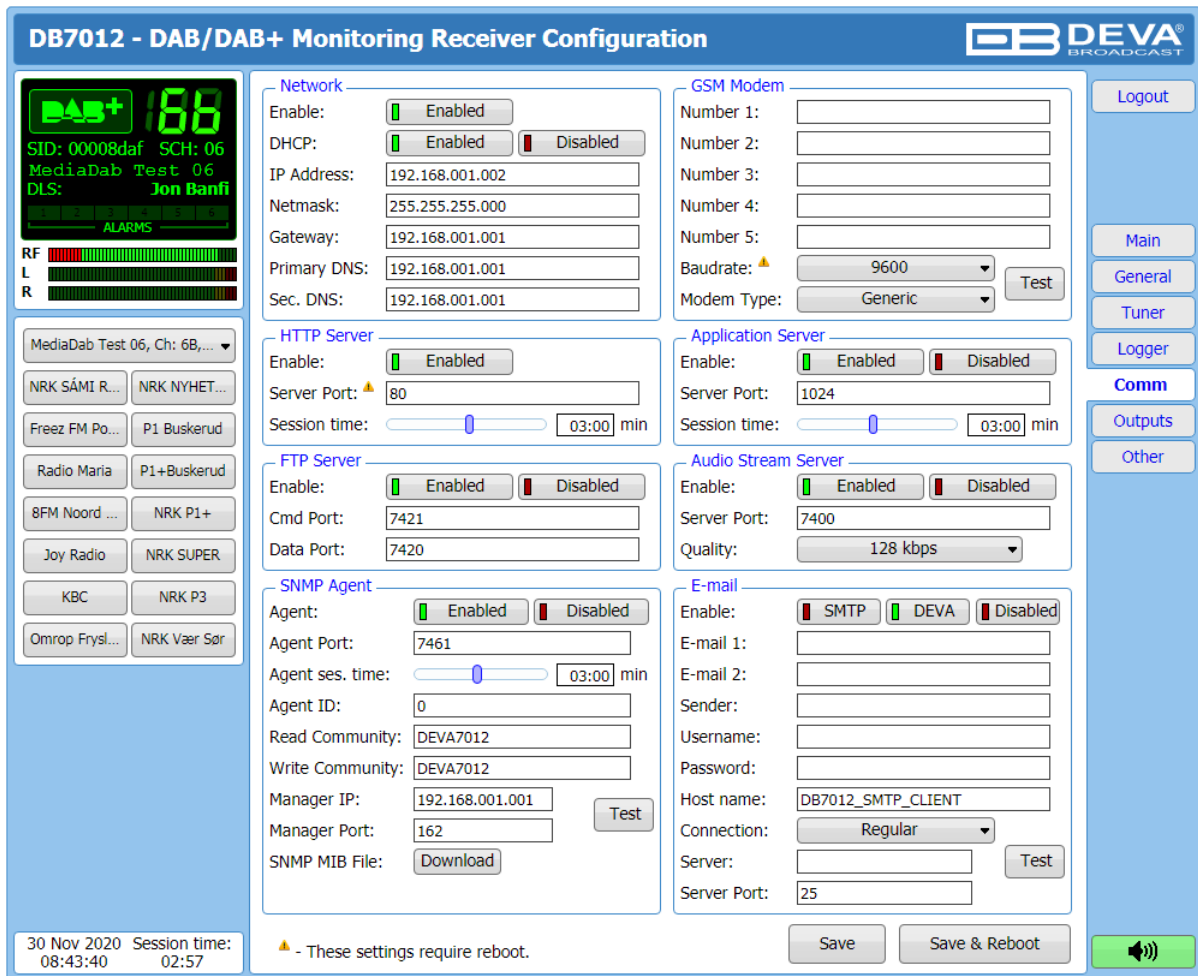

DB7012 - DAB/DAB+ Monitoring Receiver Configuration

Network
 Enable: Enabled Disabled
 DHCP: Enabled Disabled
 IP Address: 192.168.001.002
 Netmask: 255.255.255.000
 Gateway: 192.168.001.001
 Primary DNS: 192.168.001.001
 Sec. DNS: 192.168.001.001

GSM Modem
 Number 1:
 Number 2:
 Number 3:
 Number 4:
 Number 5:
 Baudrate: 9600
 Modem Type: Generic

HTTP Server
 Enable: Enabled Disabled
 Server Port: 80
 Session time: 03:00 min

Application Server
 Enable: Enabled Disabled
 Server Port: 1024
 Session time: 03:00 min

FTP Server
 Enable: Enabled Disabled
 Cmd Port: 7421
 Data Port: 7420

Audio Stream Server
 Enable: Enabled Disabled
 Server Port: 7400
 Quality: 128 kbps

SNMP Agent
 Agent: Enabled Disabled
 Agent Port: 7461
 Agent ses. time: 03:00 min
 Agent ID: 0
 Read Community: DEVA7012
 Write Community: DEVA7012
 Manager IP: 192.168.001.001
 Manager Port: 162
 SNMP MIB File:

E-mail
 Enable: SMTP DEVA Disabled
 E-mail 1:
 E-mail 2:
 Sender:
 Username:
 Password:
 Host name: DB7012_SMTP_CLIENT
 Connection: Regular
 Server:
 Server Port: 25

30 Nov 2020 Session time: 08:43:40 02:57
 ⚠ - These settings require reboot.

Network

The network addresses could be set manually (static IP) or automatically via a DHCP server. To set static IP, MASK, GATEWAY and DNS addresses, the DHCP should be disabled. In order for the built-in DHCP client to be activated, the function should be enabled. When the DHCP client is activated, all assigned values will be shown in the relevant fields on the Status Screen. If due to any reason, the DHCP procedure cannot be completed, DB7012 will use AutoIP and will generate an IP Address.

GSM Modem

Up to five numbers for SMS control and alarm notifications could be set. Baud Rate is mandatory for the proper operation of the GSM Modem. We recommend that a test SMS to be generated (via pressing the [Test] button), once all needed settings are applied. Upon success, the SMS will be delivered to all the specified GSM numbers. Example of Test SMS Message:

DB7012 Test Message .

NOTE: The current condition of the GSM Modem could be checked in the Status Screen. For detailed information on the option, please refer to [“GSM Modem Option” on page 55](#).

HTTP Server

[Enabled] the HTTP Server. Specify the Server Port and session timeout. If the [Enabled] button is not illuminated in green, the option is disabled.

FTP Server

[Enabled]/[Disabled] the FTP Server. Specify the Command and Data Ports to be used.

Audio Stream Server

[Enabled]/[Disabled] the Audio Stream Server. Then specify Port for audio Streaming, and Quality (64, 96, 128, 192 or 256 kbps). The Audio Stream could be heard using suitable audio player (Media Player, Winamp, etc.) or through the WEB interface by pressing the [Listen] button.

SNMP Agent

Agent – [Enabled]/[Disabled] the SNMP Agent.

Specify Agent ID, Agent Port, Read/Write Communities, Manager IP, Manager Port and session timeout. Agent ID is used for identification of the device among others, when an SNMP notification is being sent.

Once all needed settings are applied, use the [Test] button to generate a test notification, which upon success will be received by the SNMP Manager.

Press the [Download] button to download the latest available DB7012 SNMP MIB file.

NOTE: The MIB file may vary from one firmware revision to another. Downloading this file from the device, guarantees that you have the proper MIB file.

E-mail

To use the email notification option, please make sure it is [Enabled] by pressing the relevant button. Then follow the instructions below:

1. Enter the desired alarm recipients in e-mail 1 and/or e-mail 2 fields.
2. Fill in your e-mail account settings: Sender, Username and Password, Server, SNMP port and connection type.
3. It is mandatory the type of connection with the server to be specified from Connection - Regular, Encrypted.
4. The Server port will be changed accordingly. Please note that the most commonly used port will be entered in the field. If the port that is to be used is different, change it manually to the correct value.
5. We recommend you to use the [Test] button and generate a test e-mail, which upon success will be delivered to the specified E-mail 1 and/or E-mail 2. Example of Test E-mail Message:

DB7012 Test Message.

Please do not reply to this e-mail.

If you experience difficulties in the set-up, or would like to use DEVA account for sending of alarm email notifications, press the [DEVA] button option, and:

1. Complete the recipient emails (E-mail 1 and E-mail 2) only.
2. The other fields must be left blank, otherwise the email notification option will not be working.
3. We recommend you to use the [Test] button and generate a test e-mail, which upon success will be delivered to the specified E-mail 1 and/or E-mail 2. Example of Test E-mail Message:

DB7012 Test Message.

Please do not reply to this e-mail.

Even though using the DEVA account eases the set-up process, we recommend user account to be used for sending of email notifications, and the DEVA account for test purposes. When using DEVA account, please note that the stable 24/7 connection depends on the mail service provider and cannot be guaranteed.

NOTE: In order for the applied settings to be used press the [Save] button, placed on the bottom right part of the screen.

OUTPUTS SETTINGS

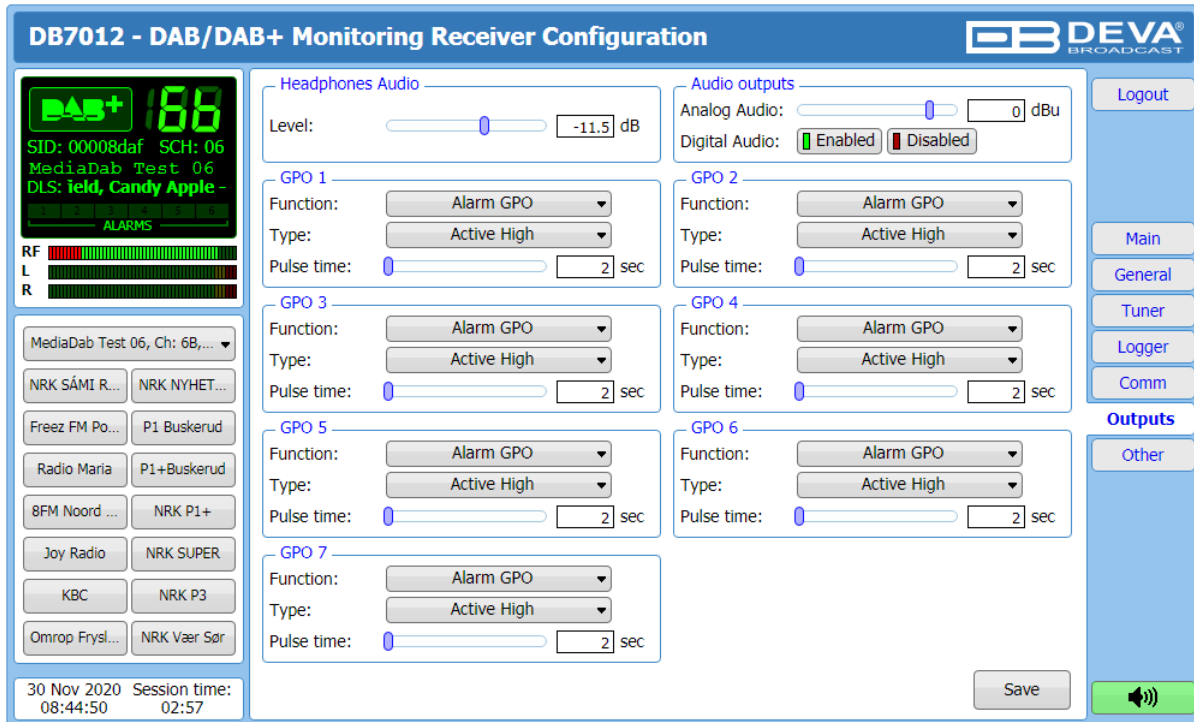

The general purpose outputs settings are applied through this page. Function, type and pulse time for each of the GPOs could be set individually. You can choose between the available functions. Type is used for specifying of the active level. When an alarm is generated the output can change the level to Active High/Low or to generate High/Low Pulse.

PLEASE NOTE that if the GPO's function is not assigned as Alarm GPO and is chosen as a preferred alarm, notifications will not be indicated, nevertheless one is being generated.

The Outputs page also allows you to set the GSM and Headphones Audio levels.

OTHER SETTINGS

DB7012 - DAB/DAB+ Monitoring Receiver Configuration

Firmware Update
Firmware file: Choose File No file chosen DSP: 1.1rc.1841 2020/06/23
TUN: 1.1rc.1841 2020/06/23
LIB: 1.1rc.1861 2020/10/09
Upload

Storage
Used Space: 364.81 MB Format
Free Space: 7013.19 MB

System Log
Clear

Factory Defaults
All except IP

Reboot Device
Reboot

Logout
Main
General
Tuner
Logger
Comm
Outputs
Other

MediaDab Test 06, Ch: 6B, ...
NRK SÁMI R... NRK NYHET...
Freez FM Po... P1 Buskerud
Radio Maria P1+Buskerud
8FM Noord ... NRK P1+
Joy Radio NRK SUPER
KBC NRK P3
Omrop Frysl... NRK Vær Sør

30 Nov 2020 Session time:
08:46:24 02:54

Firmware Update

To update the device firmware, select the new firmware file. After having pressed the Upload button, a dialog window will appear. Confirm the firmware update and wait for the process to complete. Information on current DSP1, DSP2 and WEB version is also found in this section.

Storage

Information about the device storage space is found in this section. The entire internal storage could be deleted by pressing the [Format] button.

System Log

By pressing the [Clear] button, all records in the system log will be deleted.

Factory Defaults

[All except IP] – all settings, except for the Network settings (IP Address) will be deleted.

To restore DB7012 to its Factory Defaults, press [All except IP]. A new window will appear – confirm that you want to restore the factory defaults and wait for the process to be completed. On completion of the process, the settings should have the proper default values.

Reboot

To start Rebooting of DB7012, press the [Reboot] button. A dialog warning window will appear. Confirm that you want to reboot the device and wait for the process to be completed.

APPENDIX B

ALARM TRIGGERS

After collecting all the data, the DSP-based core compares the values measured with the predefined by the user threshold levels, for all the alarms monitored. In case that a parameter is beyond limits, the device will initiate the sending of an alarm notification via the selected communication path. All the alarm events are stored in the device's log. It is essential that, if there is a very short fault of the signal, with duration shorter than the 'alarm trigger time', the device would not trigger an alarm.

There are several Alarm Triggers for the following parameters: RF, DAB, DAB SNR, DAB CNR, Left/Right, FIC Quality. An option for defining different limits for each of the parameters is present. All these values, the 'trigger time' and the 'release time' have to be assigned separately for each of the alarms.

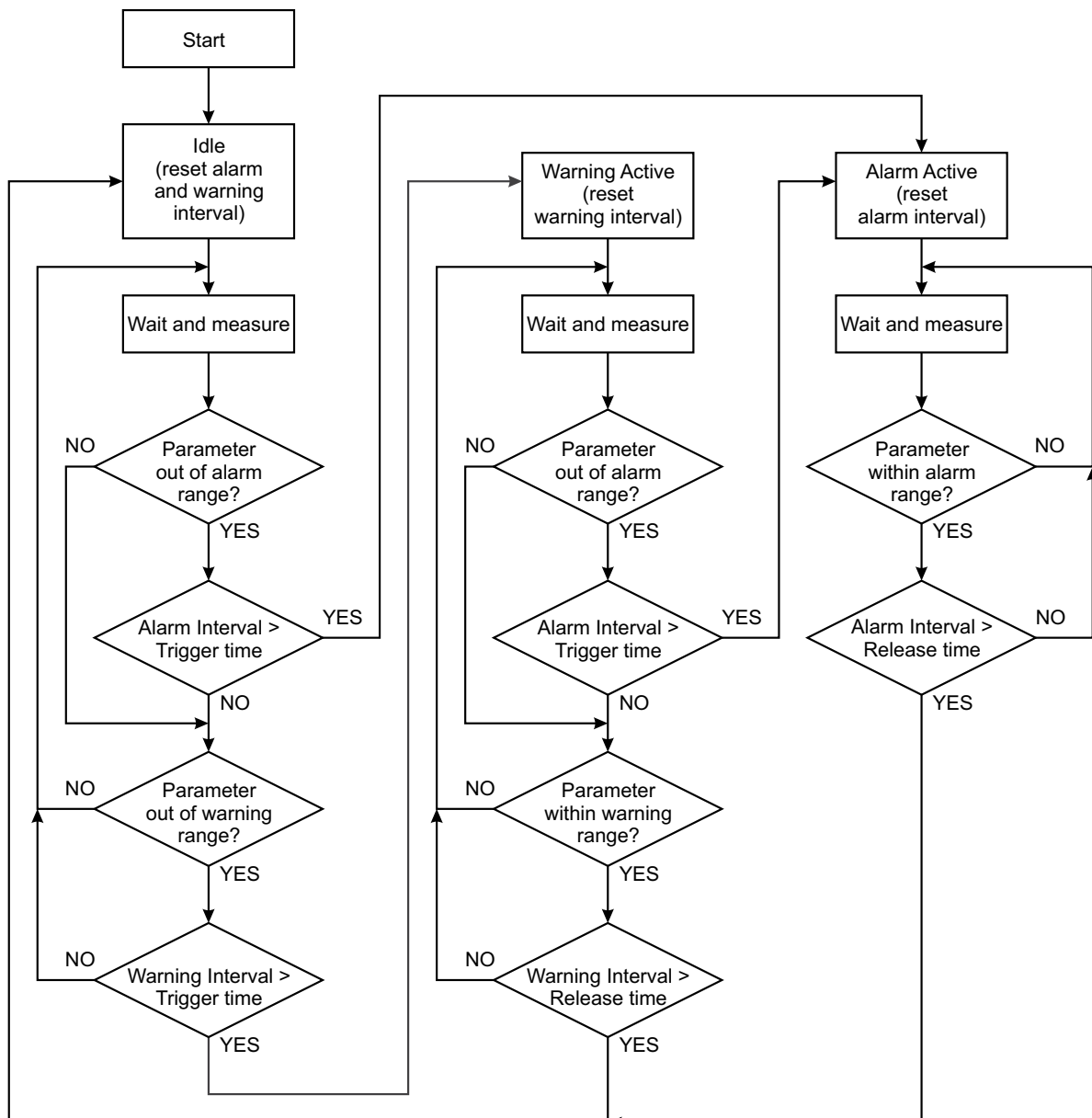

Block Diagram of Alarm Automata

When an observation event takes place, the Alarm Trigger's State will refresh, if necessary. Should we consider an instance when the Alarm Trigger is in Idle state, having in mind that an alarm is not triggered immediately when a parameter level passes beyond threshold: If the parameter level becomes stable, within Thresholds, and the Alarm Trigger Time is not elapsed, then the Alarm Trigger remains in Idle state. If the Alarm Trigger Time expires and the parameter level is still beyond limits, the Alarm Trigger would change its state to High/Low. This would result in predefined actions - Alarm Notifications (E-mail, SMS, SNMP trap) and Save a Log Record. The state will not be immediately switched into Idle when the parameter stabilizes, within Threshold levels, not up until the 'Alarm Release Time' is elapsed. Meanwhile, if the parameter crosses again any Threshold, the Alarm Trigger will remain in Active state. If the parameter remain within the Threshold levels and the Alarm Release Time expires, then the Alarm Trigger would switch into Idle state and again predefined actions would be initiated.

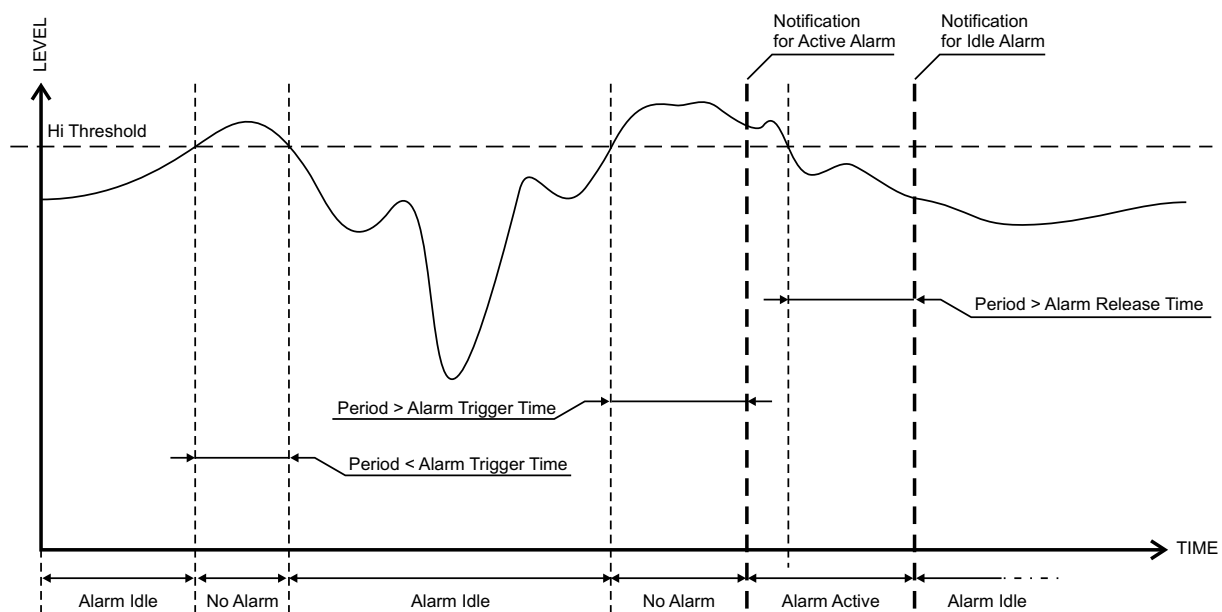

ALARM NOTIFICATIONS

The E-mail, SMS, SNMP trap Alarm Notifications contain the following information - device's Alias, date and time of Alarm triggered, channel number, frequency and information about the Alarm activation/deactivation. The basic signal parameters are also included.

Example for E-mal Notification:

Date: 04 Nov 2018, 07:31:11

DB7012 reports ACTIVE alarm on 0x1234 - Power FM (CH1)

Alarm: S/N Ratio < 16dB

Signal parameters:

RF: 31dBuV

DAB: LOSS

S/N Ratio: 0dB

CNR: 0dB

Left: -60.0dB

Right: -60.0dB

FIC Quality: 0%

Example for SMS Notification:

ACTIVE ALARM:CH1

27.09.2018 09:08:34

SERV:0x1234

RF:31dBuV

DAB:LOSS

SNR:0dB *L*

CND:0dB

Left:-60.0dB

Right:-60.0dB

FICQ:0%

NOTE: *L* for LOW (below threshold), *H* for HIGH (above threshold)

ATTENTION: Because of the SMS length limitations, only the most important parameters are included.

APPENDIX C

GSM MODEM OPTION - FEATURES AND USAGE

The described Features and Usage of the GSM Option is compatible with following DEVA Units:

- **DB46** – Compact DAB/DAB+ Monitoring Receiver
- **DB7012** – Professional DSP-based DAB/DAB+ Monitoring Receiver

The DEVA DAB/DAB+ Monitoring receivers supports a very wide range of GSM Modems. However, we suggest the usage of the following model - Sierra Wireless AirLink. This is the modem that is provided from DEVA Broadcast if the feature has been ordered along with the DEVA Units.

The GSM modem model is directly PIN to PIN compatible with the DEVA Units GSM Modem's connector, and by simply using a direct cable, you will have not any troubles with the data communication and audio insertion.

Before connecting the GSM Modem to the DEVA Unit, it is necessary to set up the parameters for normal operation. Please bear in mind that:

- GSM modem does not have an automatic detection of the baud rate (AUTOBAUD function). The most important thing is to set up the GSM Modem communication settings. The Communication speed must be 9600 bps, Data Bits: 8; Parity: None; Stop Bits:1.
- The SIM Card PIN code must be disabled in order to avoid a configuration problem of the modem. We suggest you to do this procedure using a GSM phone device of choice. This will save you a lot of time for reading the GSM Modem documentation. In case you decide to do that using the GSM Modem please refer to its User Manual for details.

IMPORTANT: Once the GSM modem is properly installed, the DEVA Unit must be pre-configured to receive messages from up to 5 authorized numbers. This can be made via the WEB interface of the device. Upon successful installation, a notification message will appear on the unit's LCD/OLED screen (if such is available). Using this screen you can find the best place with good GSM Network coverage for the installation of the GSM modem.

NOTE: For information, how the DEVA Unit can be accessed via the WEB Interface, please refer to the respective quick user guide for the device in question. All the documents are available at www.devabroadcast.com/downloads

REMOTE STATUS REQUEST

The described Feature is compatible with following DEVA Units:

- **DB46** – Compact DAB/DAB+ Monitoring Receiver
- **DB7012** – Professional DSP-based DAB/DAB+ Monitoring Receiver

The DEVA Unit can send you a report with the values of the most important parameters at any time. Upon receiving your request via SMS, the device's tuner will be adjusted on the requested service number and will make measurement of all the available parameters. Once the procedure is completed, an SMS message will be generated and sent to the requestor's GSM. Command Example:

Status **F**

IMPORTANT:

Where **F** is service number (preset number set in the device) to Tune.

Do not include leading zeroes such as "Status 06"

The Device will shortly respond back with SMS with the available parameters.

INITIALIZATION PROCEDURE FOR SIERRA WIRELESS AIR-LINK FXT009 GSM MODEM

in regards with the following DEVA Units:

- **DB46** – Compact DAB/DAB+ Monitoring Receiver
- **DB7012** – Professional DSP-based DAB/DAB+ Monitoring Receiver

1. Setting up the modem

Prior to connecting/using the GSM modem for the first time, kindly read the manufacturer’s user manual. The document can be found on https://source.sierrawireless.com/resources/airlink/hardware_reference_docs/airlink_fxt_series_user_guide/

The appropriate values should be assigned via the RS232 interface of the GSM modem. A custom made cable and a terminal program of any kind should be used. The cable specifications should be as follows:

To PC DB 9 female pin		GSM modem DB 15 male pin	Note
1	->	1	Data Carrier Detect
2	->	6	com TX
3	->	2	com RX
4	->	8	DTR
5	->	9	GND
6	->	7	DSR
7	->	12	RTS
8	->	11	CTS
9	->	13	RI

Next, the following settings should be applied to the terminal program:

Speed	115200 bps.
Flow control	hardware (CTS/RTS)
Parity	none
Data bits	8
Stop bits	1

To check the communication type the command “AT” in the terminal program and press Enter. The modem will/should respond with “OK”.

Upon powering on, the modem should start working with its factory settings. To see these settings type the command “AT&V”. The modem will respond with the factory default settings:

```
Q:0 V:1 S0:000 S2:043 S3:013 S4:010 S5:008  
+CR:0 +CRC:0 +CMEE:0 +CBST:0,0,1  
+SPEAKER:1 +ECHO:0 &C:0 &D:2 %C:0  
+IPR:115200 +ICF:3,4 +IFC:2,2
```

ATTENTION: If the displayed parameters differ from one listed above, we recommend you to return the modem to its factory defaults. In order for this to happen, the command “AT&F1” should be typed.

NOTE: For further information on the AT commands, please refer to the GMS Modem complete user manual.

Once the modem is returned to its factory defaults, you can proceed with following commands:

COMMAND	DESCRIPTION	NOTE
ATE0	This command will turn Echo Off	
AT+ICF=3,4	8n1, no parity	
AT+IFC=0,0	no flow control	
AT+IPR=9600	set com speed	Change terminal speed to 9600 bps (if needed)
AT&W	save configuration	After this command turn power Off and On
AT&V	display new configuration	

NOTE: After every command, the modem should respond with “OK”.

Once all changes/modifications are applied, the modem should respond with the following adjustments:

```
Q:0 V:1 S0:000 S2:043 S3:013 S4:010 S5:008  
+CR:0 +CRC:0 +CMEE:0 +CBST:0,0,1  
+SPEAKER:1 +ECHO:0 &C:1 &D:2 %C:0  
+IPR:9600 +ICF:3,4 +IFC:0,0
```

Upon applying all the described settings, the modem should be fully compatible for operation with DEVA Unit.

2. Connecting with DEVA Unit

Communication Cable Description:

DEVA Unit port DB 15 female pin		GSM modem DB 15 male pin	Note
2	->	2	com TX
4	->	4	mic (+)
5	->	5	mic (-)
6	->	6	com RX
9	->	9	gnd

APPENDIX D

HOW SHOULD I CONFIGURE THE CONNECTION BETWEEN MY DEVA DEVICE AND AN FTP CLIENT?

In order for a connection to be established the following setting should be applied:

1. FTP Server Settings

The built-in FTP Server has four important parameters that should be configured: Command Port, Data Port, User name and Password. These parameters are to be used in the FTP client's connection configuration. Further information on how to change the FTP Server's settings and their respective default values can be found in the device's User manual.

WE RECOMMEND the usage of FileZilla (<https://filezilla-project.org>). This is a widespread open source software distributed free of charge, hence available for downloading from the Internet.

NOTE: The FTP Server can manage only one connection at a time. The FTP Server works in Passive mode. Hence, the FTP Client should also be set in passive mode.

2. IP Router and Port Translation Settings

If the connection to the device is made through a Network address translation (NAT) router or firewall, the port forwarding feature of the router should be configured. The port forwarding is usually set in the firewall section of the router's menu. As each router has different port forwarding procedure, we recommend you to refer to its complete manual. To allow proper data flow through the router, the FTP Command and FTP Data ports should be open.

NOTE: The FTP port numbers to be used in the port forwarding feature configuration can be found in the device.

3. Example of FTP Client (FileZilla) Settings

In some cases, FileZilla's "Quick connect" feature is not able to connect with the DEVA unit. That is why we recommend the device to be assigned in the program manually.

Enter the FTP Client and go to: **File > Site manager > New Site**. A dialog box requiring obligatory information about the device will appear. Fill in the needed information and press "OK".

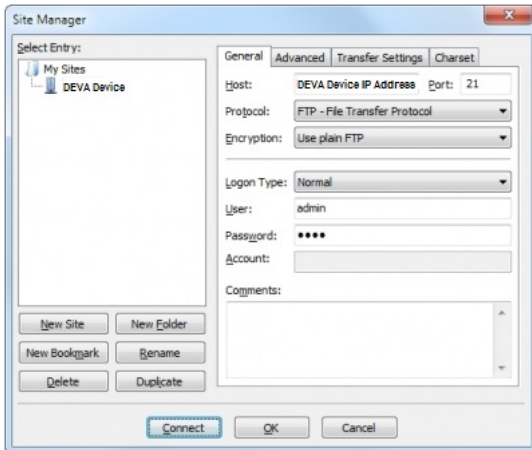

Select "Transfer Settings" sub-menu and apply the settings as shown below:

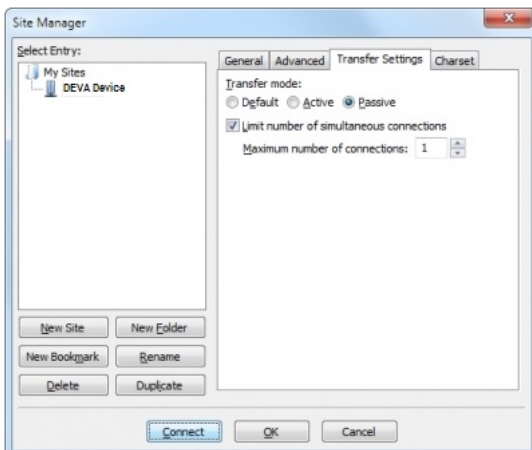

WARRANTY TERMS AND CONDITIONS

I. TERMS OF SALE: DEVA Broadcast Ltd. products are sold with an understanding of “full satisfaction”; that is, full credit or refund will be issued for products sold as new if returned to the point of purchase within 30 days following their receipt, provided that they are returned complete and in an “as received” condition.

II. CONDITIONS OF WARRANTY: The following terms apply unless amended in writing by DEVA Broadcast Ltd.

A. The Warranty Registration Card supplied with this product must be completed and returned to DEVA Broadcast Ltd. within 10 days of delivery.

B. This Warranty applies only to products sold “as new.” It is extended only to the original end-user and may not be transferred or assigned without prior written approval by DEVA Broadcast Ltd.

C. This Warranty does not apply to damage caused by improper mains settings and/or power supply.

D. This Warranty does not apply to damage caused by misuse, abuse, accident or neglect. This Warranty is voided by unauthorized attempts at repair or modification, or if the serial identification label has been removed or altered.

III. TERMS OF WARRANTY: DEVA Broadcast Ltd. products are warranted to be free from defects in materials and workmanship.

A. Any discrepancies noted within TWO YEARS of the date of delivery will be repaired free of charge, or the equipment will be replaced with a new or remanufactured product at DEVA Broadcast Ltd. option.

B. Parts and labor for factory repair required after the two-year Warranty period will be billed at prevailing prices and rates.

IV. RETURNING GOODS FOR FACTORY REPAIR:

A. Equipment will not be accepted for Warranty or other repair without a Return Material Authorization (RMA) number issued by DEVA Broadcast Ltd. prior to its return. An RMA number may be obtained by calling the factory. The number should be prominently marked on the outside of the shipping carton.

B. Equipment must be shipped prepaid to DEVA Broadcast Ltd. Shipping charges will be reimbursed for valid Warranty claims. Damage sustained as a result of improper packing for return to the factory is not covered under terms of the Warranty and may occasion additional charges.

PRODUCT REGISTRATION CARD

- All fields are required, or warranty registration is invalid and void

Your Company Name _____

Contact _____

Address Line 1 _____

Address Line 2 _____

City _____

State/Province _____ ZIP/Postal Code _____

Country _____

E-mail _____ Phone _____ Fax _____

Which DEVA Broadcast Ltd. product did you purchase? _____

Product Serial # _____

Purchase date ____ / ____ / ____ Installation date ____ / ____ / ____

Your signature*

*Signing this warranty registration form you are stating that all the information provided to DEVA Broadcast Ltd. are truth and correct. DEVA Broadcast Ltd. declines any responsibility for the provided information that could result in an immediate loss of warranty for the above specified product(s).

Privacy statement: DEVA Broadcast Ltd. will not share the personal information you provide on this card with any other parties.